

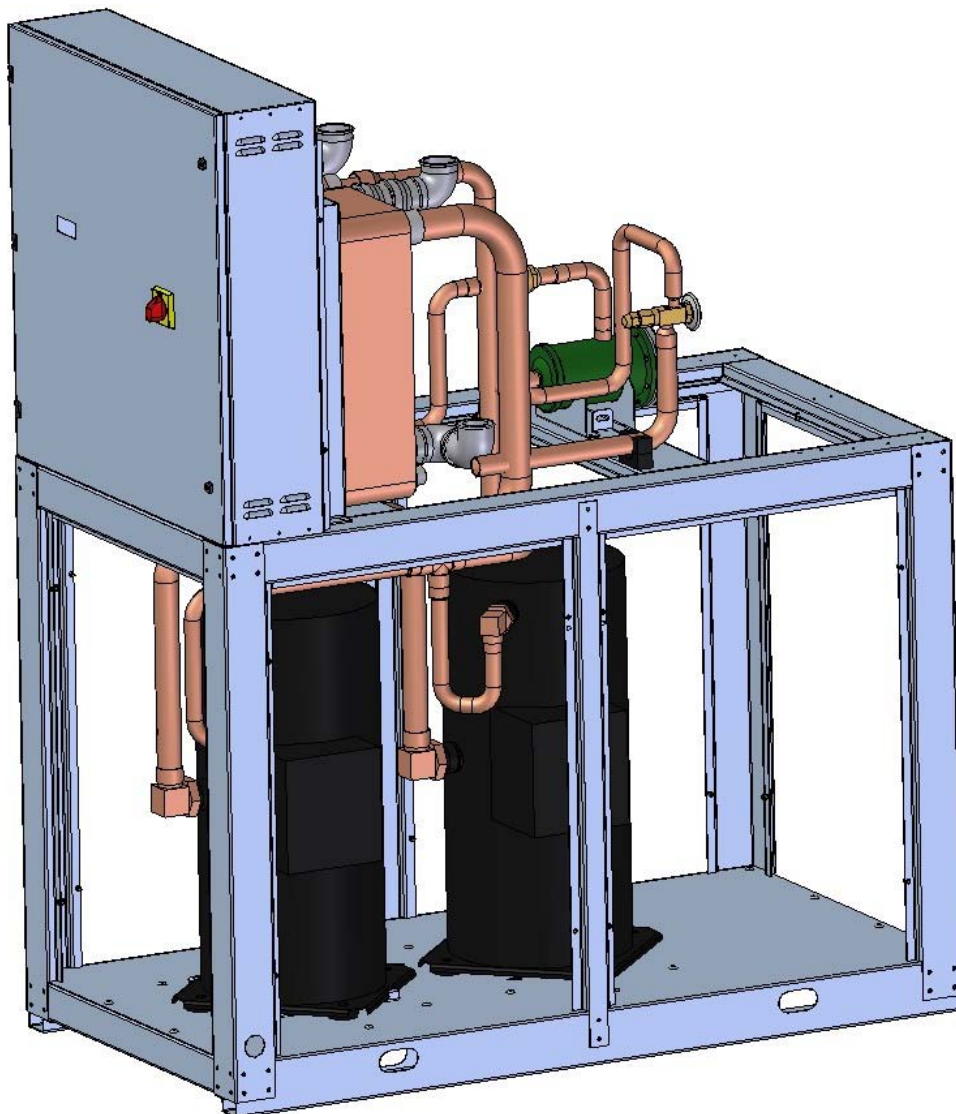

WATER TO WATER CHILLERS

WDR

SERIES



TECHNICAL MANUAL



Ferroli S.p.A.
Via Ritonda 78/A
37047 San Bonifacio (VR) Italy
tel. +39.045.6139411
fax. +39.045.6100933
www.ferroli.it



Organismo notificato / Organisme notifié
Notified body/Meldestelle/Anmält organ:

Bureau Veritas Italia

**DICHIARAZIONE DI CONFORMITA'
DECLARATION DE CONFORMITE
DECLARATION OF CONFORMITY
KONFORMITÄTSERKLÄRUNG
FÖRSÄKRAN OM ÖVERENSSTÄMMELE**

**BRUGINE
25/07/06**

Macchina Modello / Unité Modéle / UNIT Model
Gerät Typ / Enhet Modell:

Matricola / Matricule / Serial no.
Serie nummer / Serienr

Direttive CEE / Directives CEE / EEC directive / CEE Richtlinie / EEC-direktiv:

(1)

- **98/37 CE** Sicurezza delle macchine / Sécurité des machines / Safety of machinery / Sicherheit von Maschinen / Maskinsäkerhet.
 - **89/336 CE** Compatibilità elettromagnetica / Compatibilité électromagnétique / Electromagnetic compatibility / Elektromagnetische Verträglichkeit / Elektromagnetisk kompatibilitet.
 - **73/23 CE** Bassa tensione / Baisse tension / Low Voltage / Niedrige Spannung / Låg spänning
 - **97/23 CE** Dispositivi in pressione / Equipement sous pression / Under pressure devices / Drucksysteme entspricht / Tryckbärande anordnin
 - **2002/95 CE** Sostanze pericolose nelle apparecchiature elettr. / Substances dangereuses dans les équipements électr. / Hazardous substances in electr. equipment / Verwendung bestimmter gefährlicher Stoffe in der Elektronikgeräten
 - **2002/96 CE** Rifiuti di apparecchiature elettr. / déchets d'équipements électr. / Waste in electr. Equipment / Elektro- und Elektronik-Altgeräte / eller innehåller elektriska eller elektroniska produkter
- e loro successive integrazioni / et leurs intégrations suivantes / and their following amendments / und ihre folgende Verkündigungen /

- Normative - Normes - Standards - Rechtsvorschriften - Normer :

(2)

- **EN 60204-1 12/1997** Sicurezza del macchinario-Equipaggiamento elettrico-Parte 1: Regole generali / Sécurité des machines-Equipement électrique-Partie 1: Règles générales / Safety machinery-electrical equipment of machines -Part 1: General requirements / 'Sicherheit von Maschinen; elektrische Ausrüstung von Maschinen. Teil 1: allgemeine Anforderung / Maskinsäkerhet-Elutrustning för maskiner-Allmänna fordringar.
- **EN 61000-6-4 2001** Compatibilità elettromagnetica-Norma generica sull'emissione-Parte 4: Ambiente industriale / Compatibilité électromagnétique-Norme générique émission-Partie 4: Environnement industriel / Electromagnetic compatibility-Generic emission standard-Part 4: Industrial environment / Elektromagnetische Verträglichkeit-Allgemeine Bestimmung über die Emission-Teil 4: industrieller Raum / Elektromagnetisk kompatibilitet-Emission-Del 4: Generella fordringar på utrustning i industrimiljö.
- **EN 61000-6-2 2001** Compatibilità elettromagnetica-Norma generica sull'immunità-Parte 2: Ambiente industriale / Compatibilité électromagnétique-Norme générique immunité-Partie 2: Environnement industriel / Electromagnetic compatibility-Generic immunity standard-Part 2: Industrial environment / Flüssigkeitssammler* / Reciver* Elektromagnetische Verträglichkeit-Allgemeine Bestimmung über die Immunität-Teil 2: industrieller Raum / Elektromagnetisk kompatibilitet -Immunitet-Del 2: Generella fordringar på utrustning i industrimiljö.
- **EN 292/2 09/1991** Sicurezza del macchinario - Concetti fondamentali, principi generali di progettazione. Specifiche e principi tecnici. / Critères fondamentaux, principes généraux de projet. Specifications et principes techniques. / Safety of machinery - Basic concepts, General principles for design Part 2: Technical principles specification / Grundbegriffe, allgemeine. Gestaltungsleitsätze, technische Leitsätze und Spezifikationen. Maskinsäkerhet-Grundläggande begrepp, allmänna konstruktionsprinciper-Del 2: Tekniska principer
- **EN 294 06/1992** Sicurezza del macchinario - Distanze di sicurezza per impedire il raggiungimento di zone pericolose con gli arti superiori. Distances de sécurité pour empêcher le contact des membres supérieurs avec des zones dangereuses. Safety standards (avoidance of personal injury). / Sicherheitsabstände gegen das Erreichen von Gefahrenstellen mit den oberen Gliedmaßen. / Maskinsäkerhet-Skyddsavstånd för att hindra att man når riskområden med händer och armar.
- **EN 349 04/1993** Sicurezza del macchinario - Spazi minimi per evitare lo schiacciamento di parti del corpo umano. / Espaces minimum pour éviter l'écrasement de parties du corps. / Safety of machinery - Minimum gaps avoid crushing of parts of the human body / Mindestabstände zur Vermeidung des Quetschens von Körpersteilen. / Maskinsäkerhet-Minimiumtrymme för att undvika att kroppsdelar krossas.
- **EN 378-2 01/2001** Dispositivi in pressione - Impianti di refrigerazione e pompe di calore: requisiti di sicurezza e ambientali - Parte 2: progettazione, costruzione, collaudo, installazione, marcatura e documentazione / Systèmes de réfrigération et pompes à chaleur - prescriptions en matière de sécurité et d'environnement 2e partie: conception, construction, test, installation, marquage et documentation / Refrigeration systems and heat pumps - Safety and environmental requirements - Part 2: design, construction, test, instation, marking and documentation / Kältemaschinen und Wärmepumpen - Sicherheits und Umweltbestimmungen - Teil 2: Design, Konstruktion, Abnahmeprüfungen, Installation, Kennzeichnung und technische Unterlagen / Kylsystem och värmepumpar - säkerhets och miljökrav - Del 2: design, konstruktion, provning, installation, märkning och dokumentation.

Moduli di valutazione di conformità alla direttiva 97/23 utilizzati per i componenti
Formulaire de évaluation de conformité avec la directive 97/23 CEE utilisés pour les composantes
Procedures in compliance with 97/23 CEE directive to be used for the components
Konformitätprozedur nach der Richtlinie 97/23 CEE für die bauteile
Metod i överrenstämmande med 97/23 CEE standard som används för komponenter

Componente / Composant / Component / Bauteil / Komponent	Modulo/Proced./Proced./Prozed./Metod
Compressore / Compresseur / Compressor / Verdichter / Kompressor	D1
Evaporatore / Evaporateur / Evaporator / Verdampfer / Förångare	B+D / NA**
Condensatore / Condenseur / Condenser / Verflüssiger / Kondensator	B+D / NA**
Ricevitore* / Réservoir de liquide* / Liquid receiver* / Flüssigkeitssammler* / Reciver*	B+D / NA**
Separatore* / Separateur de liquide* / Liquid separator* / Abscheider* / Vätskeavskiljar	A1
Valvola sicurezza* / Vanne securité* / Safety valve* / Sicherheitsventil* / Säkerhetsventi	B+D
Pressostati di sicurez./ Pressostats / Safety pressure switch / Druckschalter / Pressosta	B+D
* se presente / si present / if presents / wenn vorhanden / om sådan finns monterd	
** se batteria alettata / si batterie à ailettes / if finned coil / bei beripptem register / vid lamellbatteri	

Certificato n° / Certificat n° / Certificate n° / Zertifikate N° / Certifikat n° : CE-PED-A1-HID001-05-BVI

Si dichiara, sotto la nostra responsabilità, che le forniture sopra indicate sono conformi in ogni parte alle direttive CEE di cui al punto (1). Le forniture sono state prodotte, collaudate e verificate con riferimento alle normative di cui al punto (2).

Nous déclarons sous notre responsabilité que les fournitures susmentionnées se conforment totalement aux directives CEE comme déclaré dans le point (1). Les fournitures ont été fabriquées, testées et contrôlées faisant référence aux normes susmentionnées au point (2).

We declare under our responsibility that the a.m. supplies are fully in conformity with the EEC regulations stated in the point (1). The equipment(s) have been manufactured, tested and checked following the standards stated in the point (2).

Wir bestätigen auf unsere Verantwortung, daß die oben angeführten Lieferungen den im Punkt (1) berichteten CEE Rechtsvorschriften voll entsprechen. Die Geräte wurden in Bezug auf die im Punkt (2) berichteten Vorschriften erzeugt und geprüft.

Vi försäkrar härmed att ovan nämnda produkter överensstämmer helt och hållet med de EEC-direktiv som anges i (1). Produkterna är tillverkade, testade och kontrollerade enligt de normer som anges i (2).

INDEX

Declaration of conformity	page 3
Aim and contents of this manual	page 6
How to keep this manual	page 6
Graphic symbols	page 6
Safety laws	page 7
General safety guidelines	page 7
Workers' health and safety	page 8
Protective equipment	page 8
Safety signs	page 8
Technical characteristics	page 9
Technical data	page 11
WDR cooling capacity and compressors input power	page 13
WDR/EV cooling capacity and compressors input power	page 16
Condenser water pressure drops	page 20
Evaporator water pressure drops	page 21
Refrigerant layouts	page 22
Partial heat recovery capacity	page 24
Water pumps available static pressure	page 25
Operation limits	page 26
Compressors capacity step controls	page 27
Corrections tables	page 27
Sound Data	page 28
Safety Device Setting	page 29
Electric data	page 29
Inspection	page 29
Lifting and handling	page 29
Location and minimum technical clearances	page 30
Hydraulic circuit	page 31
WDR / EV refrigerant connections	page 33
Unit display	page 35
Electrical connections	page 36
Start up	page 36
Maintenance and periodic checks	page 37
Refrigerant circuit repair	page 38
Environment protection	page 38
Unit out of service	page 38
Fault finding	page 38
Dimensions	page 39

The WDR manual, contains any information that is needed for a correct use of the equipment while safeguarding operator safety, according to what indicated from "Council Directive" 98/37/CE and following changes.

AIM AND CONTENTS OF THIS MANUAL

This manual provides basic information on the installation, operation and maintenance off the WDR unit. It is addressed to machine operators and it enables them to use the equipment efficiently, even if they do not have any previous specific knowledge of it.

This manual describes the characteristics of the equipment at the time it is being put on the market; therefore it may not capture later technological improvements introduced by HIDROS SRL as part of its constant endeavour to enhance the performance, ergonomics, safety and functionality of its products.

HOW TO KEEP THIS MANUAL

The manual must be always with the unit it refers to. It must be stored in a safe place, away from the dust and moisture. It must be accessible to all users who shall consult it any time they are in doubt on how to operate the equipment.

HIDROS SRL reserves the right to modify its products and related manuals without necessarily updating previous versions of the reference material. The customer shall store any updated copy of the manual or parts of it delivered by the manufacturer as an attachment to this manual.

HIDROS SRL is available to give any detailed information about this manual and to give information regarding the use and the maintenance of its own units.

GRAPHIC SYMBOLS



Indicates operations that can be dangerous for people and/or disrupts the correct operation of the equipment..



Indicates prohibited operations.



Indicates important information that the operator must follow in order to guarantee the correct operation of the equipment in complete safety

SAFETY LAWS

HIDROS SRL's equipment and their component parts have been designed in compliance with the harmonised EC norms in force and other European and national norms as required by the Council Directive (98/37 and later amendments).

The equipment is also compliant with:

- Norms EN 292-1 e 292-2
- Norma EN 294
- Norms EN 378-1, 378-2, 378-3 e 378-4
- Norma EN 418
- Norma EN 953
- Norma EN 1050
- Norma EN 60204-1
- Norma EN 61000-6-2
- Norma EN 61000-6-4
- Community Directives 98/37/CE, 97/23/CE, 93/68/CEE, 89/336/CEE 73/23/CEE

GENERAL SAFETY GUIDELINES

Before beginning to operate on WDR units every user must be perfectly knowledgeable about the functions of the equipment and its controls and must have read and understood the information contained in this manual.



It's strictly forbidden to remove and/or tamper with any safety device.



Any routine or non-routine maintenance operation shall be carried out when the equipment has been shut down, disconnected from electric and pneumatic power source and after its pneumatic system has been discharged.



Do not put your hands or insert screwdrivers, spanners or other tools into moving parts of the equipment.



The equipment supervisor and the maintenance man must receive training suitable for the performance of their tasks in safety



Operators must know how to use personal protective devices and must know the accident-prevention guidelines contained in national and international laws and norms.

WORKERS' HEALTH AND SAFETY

The European Community has adopted a number of directives on workplace health and safety, which include directives 89/391/CEE, 89/686/CEE, 89/655/CEE, 86/188/CEE and 77/576/CEE. Every employer shall implement such provisions and ensure that workers respect them:



Do not tamper with or replace parts of the equipment without the specific consent of the manufacturer. The manufacturer shall have no responsibility whatsoever in case of unauthorised operations.



Using components, expendable materials or spare parts that do not correspond to those recommended by the manufacturer and/or listed in this manual may be dangerous for the operators and/or damage the equipment



The operator's workplace must be kept clean, tidy and free from objects that may hamper free movements. Appropriate lighting of the work place shall be provided so as to allow the operator to carry out the required operations safely. Poor or too strong lighting can cause risks.



Ensure that work places are always adequately ventilated and that aspirators are working, in good condition and in compliance with the requirements of the laws in force..

PROTECTIVE EQUIPMENT

When operating and maintaining the WDR unit, use the following personal protective equipment.



Protective clothing: Maintenance men and operators must wear protective clothing that complies with the basic safety requirements currently in force. In case of slippery floors users must wear safety shoes with non-slip soles.



Gloves: During maintenance or cleaning operation protection gloves must be used



Mask and goggles: Respiratory protection (mask) and eye protection (goggles) should be used during cleaning and maintenance operations.

SAFETY SIGNS

The equipment features the following safety signs, which must be complied with:



General hazard



Electric shock hazard

TECHNICAL CHARACTERISTICS

Frame

All WDR units are made from hot-galvanised thick sheet metal, painted with polyurethane powder enamel at 180°C to ensure the best resistance against the atmospheric agents. The frame is self-supporting with removable panels. All screws and rivets are in stainless steel. The colour of the units is RAL 7035.

Refrigerant circuit

The refrigerant gases used in these units is R407C. The refrigerant circuit is made by using international primary brands components and according to ISO 97/23 concerning welding procedures. Each refrigerant circuit is totally independent from the other. Any incorrect operation of one circuit does not influence the other circuit. The refrigerant circuit includes:

- sight glass,
- filter drier,
- thermal expansion valve with external equalizer,
- Schrader valves for maintenance and control,
- pressure safety device (according to PED regulation).

Compressors

The WDR units are supplied with scroll type compressors. Compressors are supplied with crankcase heater and thermal overload protection by a klixon embedded in the motor winding. The compressors used are all in tandem execution. This solution allows much higher efficiencies in partial loads compared to the units with independent refrigerant circuits. In all units the crankcase heaters are always powered when the compressors are in stand-by. The inspection to the internal components is possible through the frontal and the side panels of the unit.

Condensers

The condensers are made of AISI 316 stainless steel braze-welded plates type. From size 039 to size 162 they are single water side circuit, from the size 144 they are double circuit "cross flow" type. The use of these kind of heat exchangers allows a massive reduction of the refrigerant charge of the unit compared to the traditional shell-in-tube ones and increases the efficiency of the refrigerant cycle in partial loads.

Evaporators

The evaporators are made of AISI 316 stainless steel braze-welded plates type. From size 039 to size 162 they are single water side circuit, from the size 144 they are double circuit "cross flow" type. All units are supplied with sub-cooler to enhance the performance of the refrigerant cycle. The evaporators are factory insulated with flexible close cell material. The evaporators are all provided with a temperature sensor as antifreeze protection.

Electric enclosure

The electric switch board is made according to electromagnetic compatibility norms CEE 73/23 and 89/336. The accessibility to the board is possible after removing the front panel of the unit and the OFF positioning of the main switch. The moisture protection degree is IP55. In all WDR units are installed, standard, the compressors sequence relay who disables the operation of the compressor in case the power supply phase sequence is not the correct one (scroll compressors in fact, can be damaged if they rotate reverse wise). The following components are also standard installed: main switch, magnetic-thermal switches as a protection of compressors and pump (where present), control circuit automatic breakers, compressor contactors, pump contactor. The terminal board is supplied with voltage free contacts for remote ON-OFF and general alarm.

Microprocessors

All WDR units are supplied standard with microprocessor controls. The microprocessor controls the following functions: regulation of the water temperature, antifreeze protection, compressor timing, compressor automatic starting sequence, alarm reset, potential free contact for remote general alarm, alarms and operation leds. Upon request any microprocessor can be connected to a BMS system for the remote control and management. The technical department is available to study, together with the customer, different solutions using MODBUS; LONWORKS; BACNET or TREND protocols.

Control and protection devices

All units are supplied with the following control and protection devices: Return and supply evaporator water sensors, high pressure switch with manual reset, low pressure switch with automatic reset, high pressure safety valve, compressor thermal overload protection, pump thermal overload protection (when present) , evaporator flow switch.

OTHER VERSIONS

UNIT WITH WATER PUMP (A1NT)

This version is supplied with a single centrifugal type water pump (without water tank) with a high available pressure. The pump is connected, standard, to the evaporator but, upon request, can also be connected to the condenser heat exchanger

LOW NOISE VERSION (LS)

The low noise versions (LS) includes the complete acoustic insulation of the unit (compressor + heat exchangers vanes) with insulating material made with high density media and the interposition of heavy bitume layer.

MOTOEVAPORATING UNIT VERSION (EV)

The moto evaporating unit version is supplied without refrigerant charge (only a nitrogen charge) and without condenser. The microprocessor control is present in all units.

UNIT WITH PARTIAL HEAT RECOVERY (RP)

This version is supplied with an auxiliary heat exchanger fitted in series with the unit condenser, able to produce hot water during the cooling mode operation of the unit.

**WDR WATER CHILLERS
TECHNICAL DATA**

Mod.		039	045	050	060	070	080	090	110	120	130
Refrigerant		R407C	R407C	R407C	R407C	R407C	R407C	R407C	R407C	R407C	R407C
Cooling capacity	Kw	41,1	50	58	64,6	71,2	86,9	101,2	115,5	130,3	145,1
Compressors input power	Kw	9,8	11,9	13,5	15,3	17,0	20,3	23,6	27,0	30,3	33,6
E.E.R.	W/W	4,19	4,20	4,30	4,22	4,19	4,28	4,29	4,28	4,30	4,32
User water flow rate	l/h	7069	8600	9980	11110	12245	14950	17400	19870	22415	24960
Source water flow rate	l/h	8760	10650	12300	13750	15170	18440	21470	24510	27630	30740
Total input current	A	27,0	30,6	32,0	34,7	37,4	47,2	53,9	58,4	67,3	76,4
Total peak current	A	116,0	143,0	149,0	189,0	194,0	230,0	257,0	266,0	313,0	324,0
Maximum input current	A	34,0	40,0	44,0	49,0	54,0	64,0	73,0	82,0	93,0	104,0
Power supply	V/Ph/Hz	400/3/50									
Compressor	type	Scroll									
	n°	2	2	2	2	2	2	2	2	2	2
Refrigerant circuit	n°	1	1	1	1	1	1	1	1	1	1
Step controls	n°	2	2	2	2	2	2	2	2	2	2
Sound power level ⁽¹⁾	dB(A)	80	80	81	82	82	83	83	84	84	85
Sound pressure level ⁽²⁾	dB(A)	52	52	53	54	54	55	55	56	56	57
Water pump (option)	Kw	1,1	1,1	1,1	1,1	1,1	1,5	1,5	2,2	2,2	2,2
Water pump input current	A	2,9	2,9	2,9	2,9	2,9	2,9	4,3	5,3	5,3	5,3
Weight (LS configuration)	Kg	470	500	520	540	570	590	650	660	720	770

Mod.		152	162	144	164	190	210	240	260	300	320
Refrigerant		R407C	R407C	R407C	R407C	R407C	R407C	R407C	R407C	R407C	R407C
Cooling capacity	Kw	162,8	180,5	158,1	173,8	202,4	231,1	260,6	290,1	325,5	360,9
Compressors input power	Kw	36,9	40,1	37,3	40,6	47,3	54,0	60,6	67,3	73,8	80,3
E.E.R.	W/W	4,41	4,50	4,24	4,28	4,28	4,28	4,30	4,31	4,41	4,49
User water flow rate	l/h	28000	31050	27200	29900	34810	39750	44820	49900	55990	62080
Source water flow rate	l/h	34350	37950	33600	36880	42950	49040	55250	61480	68680	75890
Total input current	A	83,9	91,4	86,0	94,4	105,0	122,4	134,6	152,8	167,8	182,8
Total peak current	A	362,0	372,5	279,8	294,0	330,0	348,0	406,0	428,0	476,5	497,5
Maximum input current	A	114,5	125,0	109,6	128,0	146,0	164,0	186,0	208,0	229,0	250,0
Power supply	V/Ph/Hz	400/3/50									
Compressor	type	Scroll									
	n°	2	2	4	4	4	4	4	4	4	4
Refrigerant circuit	n°	1	1	2	2	2	2	2	2	2	2
Step controls	n°	2	2	4	4	4	4	4	4	4	4
Sound power level ⁽¹⁾	dB(A)	85	85	85	85	86	88	88	88	90	90
Sound pressure level ⁽²⁾	dB(A)	57	57	57	57	58	60	60	60	62	62
Water pump (option)	Kw	2,2	2,2	2,2	3,0	3,0	3,0	4,0	4,0	4,0	5,5
Water pump input current	A	5,3	5,3	5,3	9,6	9,6	9,6	9,6	9,6	9,6	13,2
Weight (LS configuration)	Kg	790	820	980	1030	1150	1190	1250	1320	1400	1490

Performances are referred to the following conditions:

Cooling: evaporator water temperature in/out 12/7 °C, condenser water temperature in/out 30/35°C.

(1): Sound power level according to ISO 3746.

(2): Sound pressure level measured at 10 mt from the unit in free field conditions direction factor Q=2 according to ISO 3746.

**WDR/EV MOTOEVAPORATING UNITS
TECHNICAL DATA**

Mod.		039	045	050	060	070	080	090	110	120	130
Refrigerant		R407C	R407C	R407C	R407C	R407C	R407C	R407C	R407C	R407C	R407C
Cooling capacity	Kw	37	45,1	52,3	58,2	64,1	78,4	91,0	103,7	116,2	128,6
Compressors input power	Kw	12	14,3	16,4	18,4	20,5	24,6	28,5	32,3	36,2	40,1
E.E.R.	W/W	3,08	3,15	3,19	3,16	3,13	3,19	3,19	3,21	3,21	3,21
User water flow rate	l/h	6370	7760	9000	10000	11030	13500	15650	17840	19990	22120
Total input current	A	27,0	30,6	32,0	34,7	37,4	47,2	53,9	58,4	67,3	76,4
Total peak current	A	116,0	143,0	149,0	189,0	194,0	230,0	257,0	266,0	313,0	324,0
Maximum input current	A	34,0	40,0	44,0	49,0	54,0	64,0	73,0	82,0	93,0	104,0
Power supply	V/Ph/Hz	400/3/50									
Compressor	type	Scroll									
	n°	2	2	2	2	2	2	2	2	2	2
Refrigerant circuit	n°	1	1	1	1	1	1	1	1	1	1
Step controls	n°	2	2	2	2	2	2	2	2	2	2
Sound power level ⁽¹⁾	dB(A)	80	80	81	82	82	83	83	84	84	85
Sound pressure level ⁽²⁾	dB(A)	52	52	53	54	54	55	55	56	56	57
Water pump (option)	Kw	1,1	1,1	1,1	1,1	1,1	1,5	1,5	2,2	2,2	2,2
Water pump input current	A	2,9	2,9	2,9	2,9	2,9	2,9	4,3	5,3	5,3	5,3
Weight (LS configuration)	Kg	430	450	460	500	510	530	590	600	650	690

Mod.		152	162	144	164	190	210	240	260	300	320
Refrigerant		R407C	R407C	R407C	R407C	R407C	R407C	R407C	R407C	R407C	R407C
Cooling capacity	Kw	145,1	161,5	142,6	156,8	182,1	207,3	232,3	257,3	290,1	322,9
Compressors input power	Kw	44	47,9	45,1	49,3	56,9	64,6	72,4	80,3	88	95,8
E.E.R.	W/W	3,30	3,37	3,16	3,18	3,20	3,21	3,21	3,20	3,30	3,37
User water flow rate	l/h	24960	27780	24530	26970	31320	35660	39960	44260	49900	55540
Total input current	A	83,9	91,4	86,0	94,4	105,0	122,4	134,6	152,8	167,8	182,8
Total peak current	A	362,0	372,5	279,8	294,0	330,0	348,0	406,0	428,0	476,5	497,5
Maximum input current	A	114,5	125,0	109,6	128,0	146,0	164,0	186,0	208,0	229,0	250,0
Power supply	V/Ph/Hz	400/3/50									
Compressor	type	Scroll									
	n°	2	2	4	4	4	4	4	4	4	4
Refrigerant circuit	n°	1	1	2	2	2	2	2	2	2	2
Step controls	n°	2	2	4	4	4	4	4	4	4	4
Sound power level ⁽¹⁾	dB(A)	85	85	85	85	86	88	88	88	90	90
Sound pressure level ⁽²⁾	dB(A)	57	57	57	57	58	60	60	60	62	62
Water pump (option)	Kw	2,2	2,2	2,2	3,0	3,0	3,0	4,0	4,0	4,0	5,5
Water pump input current	A	5,3	5,3	5,3	9,6	9,6	9,6	9,6	9,6	9,6	13,2
Weight (LS configuration))	Kg	710	740	900	920	950	990	1120	1190	1250	1310

Performances are referred to the following conditions:

Cooling: evaporator water temperature in/out 12/7 °C, condensing temperature 50°C.

(1): Sound power level according to ISO 3746.

(2): Sound pressure level measured at 10 mt from the unit in free field conditions direction factor Q=2 according to ISO 3746.

**WDR - WATER CHILLERS
COOLING CAPACITY AND COMPRESSORS INPUT POWER**

Mod.	TWUC (°C)	PF (kW)						PA (kW)					
		TWIE (°C)						TWIE(°C)					
		15	20	25	30	37	45	15	20	25	30	37	45
039	5	45,2	42,7	40,3	37,8	34,4	30,6	7,3	8,0	8,8	9,9	11,7	14,3
	7	49,0	46,4	43,7	41,1	37,5	33,4	7,4	8,0	8,8	9,8	11,7	14,3
	9	53,0	50,2	47,4	44,6	40,7	36,3	7,6	8,1	8,8	9,8	11,6	14,3
	11	57,3	54,3	51,3	48,3	44,2	39,5	7,8	8,2	8,9	9,8	11,6	14,2
	13	61,8	58,6	55,4	52,3	47,8	42,8	8,0	8,3	8,9	9,8	11,6	14,2
	15	66,5	63,2	59,8	56,4	51,7	46,3	8,3	8,5	9,0	9,9	11,6	14,1

Mod.	TWUC (°C)	PF (kW)						PA (kW)					
		TWIE (°C)						TWIE(°C)					
		15	20	25	30	37	45	15	20	25	30	37	45
045	5	54,4	51,7	49,0	46,2	42,2	37,5	8,5	9,5	10,7	12,0	14,0	16,8
	7	58,8	55,9	53,0	50,0	45,7	40,7	8,5	9,5	10,6	11,9	14,0	16,8
	9	63,4	60,4	57,2	54,1	49,5	44,2	8,4	9,5	10,6	11,9	14,0	16,8
	11	68,3	65,1	61,7	58,4	53,5	47,8	8,4	9,4	10,6	11,9	14,0	16,9
	13	73,5	70,0	66,5	62,9	57,7	51,7	8,4	9,4	10,6	11,9	14,0	16,9
	15	78,9	75,3	71,5	67,7	62,2	55,8	8,4	9,4	10,5	11,9	14,0	16,9

Mod.	TWUC (°C)	PF (kW)						PA (kW)					
		TWIE (°C)						TWIE(°C)					
		15	20	25	30	37	45	15	20	25	30	37	45
050	5	63,0	60,0	56,8	53,6	49,0	43,4	9,6	10,7	12,0	13,6	16,0	19,2
	7	68,0	64,7	61,4	58,0	53,0	47,1	9,6	10,7	12,0	13,5	16,0	19,3
	9	73,2	69,8	66,2	62,6	57,3	51,0	9,6	10,7	12,0	13,5	16,0	19,3
	11	78,7	75,1	71,3	67,5	61,9	55,2	9,7	10,7	11,9	13,4	15,9	19,3
	13	84,6	80,7	76,8	72,7	66,7	59,7	9,8	10,7	11,9	13,4	15,9	19,3
	15	90,8	86,7	82,5	78,1	71,9	64,4	9,9	10,8	11,9	13,4	15,8	19,2

Mod.	TWUC (°C)	PF (kW)						PA (kW)					
		TWIE (°C)						TWIE(°C)					
		15	20	25	30	37	45	15	20	25	30	37	45
060	5	70,3	66,9	63,4	59,8	54,5	48,3	11,0	12,2	13,6	15,3	18,0	21,7
	7	75,9	72,2	68,5	64,6	59,0	52,4	11,1	12,2	13,6	15,3	18,0	21,7
	9	81,7	77,8	73,8	69,7	63,8	56,8	11,2	12,3	13,6	15,3	18,0	21,8
	11	87,9	83,8	79,5	75,2	68,9	61,4	11,3	12,3	13,6	15,3	18,0	21,8
	13	94,4	90,1	85,6	80,9	74,3	66,3	11,5	12,4	13,7	15,3	18,0	21,8
	15	101,3	96,7	91,9	87,0	80,0	71,6	11,7	12,6	13,8	15,3	18,0	21,8

Mod.	TWUC (°C)	PF (kW)						PA (kW)					
		TWIE (°C)						TWIE(°C)					
		15	20	25	30	37	45	15	20	25	30	37	45
070	5	77,7	73,8	69,9	65,9	60,1	53,2	12,4	13,7	15,2	17,0	20,0	24,1
	7	83,8	79,7	75,5	71,2	65,0	57,7	12,6	13,7	15,2	17,0	20,0	24,2
	9	90,2	85,9	81,4	76,9	70,3	62,5	12,7	13,8	15,3	17,0	20,0	24,2
	11	97,0	92,4	87,7	82,9	75,9	67,6	12,9	14,0	15,3	17,1	20,0	24,3
	13	104,3	99,4	94,4	89,2	81,8	73,0	13,2	14,1	15,5	17,1	20,1	24,3
	15	111,9	106,7	101,4	96,0	88,1	78,8	13,5	14,3	15,6	17,2	20,1	24,3

Mod.	TWUC (°C)	PF (kW)						PA (kW)					
		TWIE (°C)						TWIE(°C)					
		15	20	25	30	37	45	15	20	25	30	37	45
080	5	94,4	89,8	85,2	80,4	73,4	65,2	15,0	16,3	18,1	20,3	24,1	29,3
	7	101,8	97,0	92,0	86,9	79,5	70,7	15,3	16,5	18,1	20,3	24,0	29,3
	9	109,6	104,5	99,2	93,8	85,9	76,6	15,8	16,7	18,2	20,3	24,0	29,2
	11	118,0	112,5	106,9	101,1	92,8	82,8	16,3	17,1	18,4	20,4	23,9	29,2
	13	126,8	120,9	115,0	108,9	100,0	89,5	17,0	17,5	18,7	20,5	23,9	29,1
	15	136,0	129,9	123,5	117,0	107,7	96,5	17,9	18,1	19,1	20,7	24,0	29,1

TWUC: Evaporator outlet water temperature (°C) (Dt=5°C)
PA: Compressors input power (Kw)

TWIE: Condenser inlet water temperature (°C) (Dt=5°C)
PF: Cooling capacity (Kw)

**WDR - WATER CHILLERS
COOLING CAPACITY AND COMPRESSORS INPUT POWER**

Mod.	TWUC (°C)	PF (kW)						PA (kW)					
		TWIE (°C)						TWIE(°C)					
		15	20	25	30	37	45	15	20	25	30	37	45
090	5	110,0	104,7	99,3	93,6	85,2	75,1	17,1	18,9	21,1	23,6	27,8	33,6
	7	118,6	113,0	107,3	101,2	92,3	81,6	17,3	19,0	21,1	23,6	27,8	33,6
	9	127,7	121,8	115,7	109,3	99,9	88,6	17,4	19,1	21,2	23,7	27,8	33,7
	11	137,4	131,2	124,7	117,9	108,0	96,0	17,6	19,3	21,3	23,8	27,9	33,7
	13	147,6	141,0	134,1	127,0	116,5	103,8	17,9	19,5	21,5	23,9	28,0	33,8
	15	158,3	151,4	144,1	136,5	125,5	112,1	18,1	19,7	21,6	24,0	28,0	33,9

Mod.	TWUC (°C)	PF (kW)						PA (kW)					
		TWIE (°C)						TWIE(°C)					
		15	20	25	30	37	45	15	20	25	30	37	45
110	5	125,6	119,6	113,4	106,8	97,0	85,0	19,2	21,6	24,1	26,9	31,4	37,9
	7	135,4	129,1	122,5	115,5	105,2	92,6	19,2	21,6	24,2	27,0	31,6	38,0
	9	145,8	139,2	132,2	124,8	113,9	100,6	19,1	21,6	24,2	27,1	31,7	38,1
	11	156,8	149,8	142,4	134,7	123,2	109,1	18,9	21,5	24,2	27,2	31,8	38,3
	13	168,4	161,0	153,2	145,1	132,9	118,2	18,7	21,4	24,2	27,2	32,0	38,5
	15	180,6	172,9	164,7	156,0	143,3	127,7	18,4	21,3	24,2	27,3	32,1	38,6

Mod.	TWUC (°C)	PF (kW)						PA (kW)					
		TWIE (°C)						TWIE(°C)					
		15	20	25	30	37	45	15	20	25	30	37	45
120	5	143,5	136,0	128,2	120,2	108,6	94,7	22,1	24,5	27,1	30,2	35,3	42,6
	7	154,9	147,0	138,8	130,3	118,0	103,2	22,2	24,6	27,3	30,3	35,4	42,7
	9	167,1	158,7	150,0	141,0	127,9	112,3	22,3	24,7	27,4	30,5	35,5	42,7
	11	179,9	171,0	161,8	152,3	138,5	122,0	22,4	24,8	27,5	30,6	35,7	42,8
	13	193,5	184,1	174,3	164,3	149,7	132,2	22,4	24,9	27,7	30,8	35,8	43,0
	15	207,8	197,8	187,6	176,9	161,5	143,1	22,5	25,0	27,8	30,9	36,0	43,1

Mod.	TWUC (°C)	PF (kW)						PA (kW)					
		TWIE (°C)						TWIE(°C)					
		15	20	25	30	37	45	15	20	25	30	37	45
130	5	161,3	152,3	143,1	133,7	120,2	104,3	25,0	27,4	30,2	33,5	39,1	47,3
	7	174,4	164,9	155,1	145,1	130,7	113,9	25,3	27,6	30,4	33,6	39,2	47,3
	9	188,3	178,1	167,7	157,1	141,9	124,0	25,6	27,9	30,6	33,8	39,4	47,3
	11	203,0	192,2	181,2	169,9	153,8	134,8	25,9	28,2	30,9	34,0	39,5	47,4
	13	218,5	207,1	195,4	183,5	166,4	146,3	26,2	28,4	31,1	34,3	39,7	47,5
	15	234,9	222,8	210,5	197,8	179,7	158,4	26,5	28,8	31,4	34,5	39,9	47,6

Mod.	TWUC (°C)	PF (kW)						PA (kW)					
		TWIE (°C)						TWIE(°C)					
		15	20	25	30	37	45	15	20	25	30	37	45
152	5	178,9	169,4	159,8	150,0	135,4	117,3	27,1	29,8	33,0	36,7	42,9	51,7
	7	193,7	183,5	173,3	162,8	147,3	128,3	27,5	30,1	33,2	36,9	43,0	51,8
	9	209,4	198,6	187,6	176,4	160,0	140,0	27,8	30,4	33,5	37,1	43,2	51,9
	11	226,3	214,6	202,8	190,8	173,5	152,3	28,2	30,8	33,8	37,3	43,3	51,9
	13	244,1	231,6	219,0	206,2	187,7	165,4	28,7	31,1	34,1	37,5	43,5	52,0
	15	263,2	249,7	236,2	222,5	202,9	179,3	29,2	31,6	34,4	37,8	43,7	52,1

Mod.	TWUC (°C)	PF (kW)						PA (kW)					
		TWIE (°C)						TWIE(°C)					
		15	20	25	30	37	45	15	20	25	30	37	45
162	5	196,4	186,5	176,6	166,3	150,6	130,2	29,2	32,3	35,9	40,0	46,7	56,1
	7	212,9	202,2	191,5	180,5	164,0	142,7	29,6	32,6	36,1	40,1	46,8	56,3
	9	230,6	219,0	207,4	195,6	178,1	155,9	30,1	33,0	36,4	40,3	47,0	56,4
	11	249,5	236,9	224,4	211,7	193,1	169,8	30,6	33,4	36,7	40,6	47,1	56,5
	13	269,8	256,1	242,5	228,9	209,1	184,6	31,2	33,8	37,0	40,8	47,3	56,6
	15	291,4	276,5	261,9	247,2	226,1	200,2	31,8	34,4	37,4	41,1	47,5	56,7

TWUC: Evaporator outlet water temperature (°C) (Dt=5°C)
PA: Compressors input power (Kw)

TWIE: Condenser inlet water temperature (°C) (Dt=5°C)
PF: Cooling capacity (Kw)

**WDR - WATER CHILLERS
COOLING CAPACITY AND COMPRESSORS INPUT POWER**

Mod.	TWUC (°C)	PF (kW)						PA (kW)					
		TWIE (°C)						TWIE(°C)					
		15	20	25	30	37	45	15	20	25	30	37	45
144	5	172,0	163,7	155,1	146,3	133,5	118,3	27,5	30,0	33,3	37,3	44,1	53,4
	7	185,5	176,6	167,5	158,1	144,5	128,4	27,9	30,2	33,3	37,3	44,0	53,5
	9	199,9	190,4	180,7	170,7	156,2	139,1	28,5	30,6	33,5	37,3	44,0	53,5
	11	215,0	204,9	194,6	184,0	168,7	150,4	29,3	31,0	33,8	37,4	44,0	53,4
	13	231,0	220,3	209,4	198,1	181,8	162,5	30,2	31,7	34,2	37,6	44,0	53,4
	15	247,9	236,6	225,0	213,0	195,8	175,3	31,3	32,5	34,7	37,9	44,1	53,4

Mod.	TWUC (°C)	PF (kW)						PA (kW)					
		TWIE (°C)						TWIE(°C)					
		15	20	25	30	37	45	15	20	25	30	37	45
164	5	188,7	179,7	170,3	160,8	146,9	130,3	30,0	32,6	36,2	40,6	48,2	58,5
	7	203,6	193,9	184,0	173,8	159,0	141,4	30,7	32,9	36,3	40,6	48,1	58,5
	9	219,3	209,0	198,4	187,6	171,9	153,1	31,6	33,5	36,5	40,6	48,0	58,5
	11	235,9	225,0	213,8	202,2	185,5	165,6	32,7	34,2	36,9	40,7	47,9	58,4
	13	253,5	241,9	230,0	217,7	200,0	178,9	34,0	35,1	37,4	41,0	47,9	58,3
	15	272,1	259,7	247,1	234,1	215,3	193,0	35,7	36,2	38,1	41,4	48,0	58,2

Mod.	TWUC (°C)	PF (kW)						PA (kW)					
		TWIE (°C)						TWIE(°C)					
		15	20	25	30	37	45	15	20	25	30	37	45
190	5	219,9	209,5	198,5	187,1	170,4	150,2	34,3	37,9	42,2	47,2	55,5	67,2
	7	237,2	226,1	214,5	202,4	184,7	163,2	34,5	38,1	42,3	47,3	55,6	67,3
	9	255,4	243,7	231,4	218,6	199,8	177,2	34,8	38,3	42,5	47,4	55,7	67,4
	11	274,8	262,3	249,3	235,8	215,9	191,9	35,2	38,6	42,7	47,5	55,8	67,5
	13	295,1	282,0	268,2	253,9	232,9	207,6	35,7	39,0	42,9	47,7	55,9	67,6
	15	316,7	302,7	288,2	273,1	250,9	224,2	36,3	39,4	43,3	48,0	56,1	67,7

Mod.	TWUC (°C)	PF (kW)						PA (kW)					
		TWIE (°C)						TWIE(°C)					
		15	20	25	30	37	45	15	20	25	30	37	45
210	5	251,1	239,3	226,7	213,5	193,9	170,0	38,5	43,1	48,1	53,7	62,8	75,8
	7	270,8	258,3	245,0	231,1	210,4	185,1	38,4	43,2	48,3	54,0	63,1	76,0
	9	291,6	278,4	264,4	249,7	227,8	201,2	38,1	43,1	48,4	54,2	63,4	76,3
	11	313,6	299,6	284,9	269,3	246,3	218,2	37,8	43,0	48,5	54,4	63,7	76,6
	13	336,8	322,0	306,5	290,1	265,9	236,3	37,4	42,8	48,5	54,5	64,0	76,9
	15	361,2	345,7	329,3	312,1	286,6	255,5	36,9	42,5	48,4	54,6	64,2	77,2

Mod.	TWUC (°C)	PF (kW)						PA (kW)					
		TWIE (°C)						TWIE(°C)					
		15	20	25	30	37	45	15	20	25	30	37	45
240	5	286,9	272,0	256,5	240,4	217,2	189,3	44,3	48,9	54,2	60,3	70,5	85,2
	7	309,8	294,0	277,6	260,6	235,9	206,4	44,5	49,2	54,5	60,6	70,8	85,3
	9	334,1	317,3	299,9	282,0	255,8	224,6	44,7	49,5	54,8	60,9	71,1	85,5
	11	359,8	342,0	323,6	304,6	277,0	243,9	44,8	49,7	55,1	61,2	71,3	85,7
	13	386,9	368,1	348,7	328,6	299,3	264,4	44,9	49,9	55,4	61,5	71,7	85,9
	15	415,5	395,7	375,1	353,9	323,0	286,2	44,9	50,0	55,6	61,8	72,0	86,2

Mod.	TWUC (°C)	PF (kW)						PA (kW)					
		TWIE (°C)						TWIE(°C)					
		15	20	25	30	37	45	15	20	25	30	37	45
260	5	322,7	304,6	286,2	267,3	240,4	208,7	50,1	54,8	60,3	66,9	78,2	94,6
	7	348,9	329,7	310,1	290,1	261,4	227,8	50,6	55,2	60,7	67,3	78,5	94,6
	9	376,6	356,3	335,5	314,3	283,8	248,1	51,2	55,8	61,2	67,7	78,7	94,7
	11	406,0	384,4	362,4	339,9	307,6	269,7	51,8	56,3	61,7	68,1	79,0	94,8
	13	437,1	414,2	390,8	367,0	332,8	292,6	52,4	56,9	62,2	68,6	79,3	95,0
	15	469,8	445,6	420,9	395,7	359,5	316,9	53,0	57,5	62,8	69,0	79,7	95,2

TWUC: Evaporator outlet water temperature (°C) (Dt=5°C)
PA: Compressors input power (Kw)

TWIE: Condenser inlet water temperature (°C) (Dt=5°C)
PF: Cooling capacity (Kw)

**WDR - WATER CHILLERS
COOLING CAPACITY AND COMPRESSORS INPUT POWER**

Mod.	TWUC (°C)	PF (kW)						PA (kW)					
		TWIE (°C)						TWIE(°C)					
		15	20	25	30	37	45	15	20	25	30	37	45
300	5	357,7	338,9	319,7	299,9	270,8	234,5	54,2	59,7	66,0	73,4	85,8	103,5
	7	387,3	367,1	346,6	325,5	294,7	256,6	54,9	60,2	66,5	73,8	86,1	103,6
	9	418,9	397,1	375,2	352,7	320,0	279,9	55,6	60,8	67,0	74,2	86,3	103,7
	11	452,5	429,1	405,6	381,6	346,9	304,7	56,5	61,5	67,5	74,6	86,6	103,9
	13	488,3	463,2	438,0	412,4	375,5	330,9	57,3	62,3	68,1	75,1	87,0	104,1
	15	526,3	499,3	472,3	445,1	405,8	358,7	58,3	63,1	68,8	75,7	87,4	104,3

Mod.	TWUC (°C)	PF (kW)						PA (kW)					
		TWIE (°C)						TWIE(°C)					
		15	20	25	30	37	45	15	20	25	30	37	45
320	5	392,8	373,1	353,2	332,5	301,3	260,4	58,4	64,6	71,7	79,9	93,4	112,3
	7	425,8	404,4	383,0	360,9	327,9	285,5	59,2	65,2	72,2	80,3	93,7	112,5
	9	461,2	438,0	414,8	391,2	356,2	311,8	60,1	65,9	72,7	80,7	93,9	112,7
	11	499,0	473,8	448,8	423,4	386,3	339,7	61,1	66,7	73,3	81,1	94,2	112,9
	13	539,5	512,1	485,1	457,8	418,2	369,2	62,3	67,6	74,0	81,6	94,6	113,2
	15	582,8	553,0	523,8	494,5	452,2	400,5	63,7	68,7	74,9	82,3	95,0	113,4

TWUC: Evaporator outlet water temperature (°C) (Dt=5°C)
 TWIE: Condenser inlet water temperature (°C) (Dt=5°C)
 PA: Compressors input power (Kw)
 PF: Cooling capacity (Kw)

**WDR/EV – MOTOEVAPORATING UNITS
COOLING CAPACITY AND COMPRESSORS INPUT POWER**

Mod.	TWUC (°C)	PF (kW)						PA (kW)					
		TC (°C)						TC(°C)					
		30	35	40	45	50	55	30	35	40	45	50	55
039	5	43,7	41,2	38,8	36,4	34,0	31,6	7,7	8,4	9,4	10,6	12,0	13,6
	7	47,4	44,8	42,2	39,6	37,0	34,4	7,7	8,5	9,4	10,6	12,0	13,6
	9	51,3	48,5	45,7	43,0	40,2	37,4	7,8	8,5	9,4	10,5	11,9	13,5
	11	55,5	52,5	49,5	46,5	43,6	40,6	8,0	8,5	9,4	10,5	11,9	13,5
	13	59,9	56,7	53,5	50,4	47,2	44,0	8,2	8,6	9,4	10,5	11,9	13,5
	15	64,5	61,1	57,8	54,4	51,0	47,7	8,4	8,8	9,5	10,5	11,8	13,4

Mod.	TWUC (°C)	PF (kW)						PA (kW)					
		TC (°C)						TC(°C)					
		30	35	40	45	50	55	30	35	40	45	50	55
045	5	52,8	50,1	47,3	44,5	41,6	38,7	9,1	10,2	11,4	12,8	14,3	16,1
	7	57,1	54,2	51,2	48,2	45,1	42,0	9,1	10,2	11,4	12,8	14,3	16,1
	9	61,6	58,5	55,3	52,1	48,8	45,5	9,0	10,1	11,4	12,8	14,3	16,1
	11	66,4	63,1	59,7	56,3	52,8	49,3	9,0	10,1	11,4	12,8	14,3	16,1
	13	71,4	67,9	64,3	60,7	57,0	53,2	9,0	10,1	11,3	12,7	14,3	16,1
	15	76,7	73,0	69,2	65,4	61,4	57,4	9,0	10,1	11,3	12,7	14,3	16,1

Mod.	TWUC (°C)	PF (kW)						PA (kW)					
		TC (°C)						TC(°C)					
		30	35	40	45	50	55	30	35	40	45	50	55
050	5	61,2	58,1	54,9	51,6	48,3	44,8	10,2	11,5	12,9	14,6	16,4	18,4
	7	66,0	62,7	59,4	55,9	52,3	48,6	10,2	11,5	12,9	14,5	16,4	18,4
	9	71,1	67,7	64,1	60,4	56,6	52,6	10,2	11,4	12,8	14,5	16,3	18,4
	11	76,6	72,9	69,0	65,1	61,1	56,9	10,3	11,4	12,8	14,4	16,3	18,4
	13	82,3	78,4	74,3	70,1	65,9	61,5	10,3	11,4	12,8	14,4	16,3	18,4
	15	88,3	84,2	79,9	75,5	70,9	66,3	10,4	11,4	12,8	14,4	16,2	18,3

TWUC: Evaporator outlet water temperature (°C) (Dt=5°C)
 TC: Condensing temperature (°C)
 PA: Compressors input power (Kw)
 PF: Cooling capacity (Kw)

**WDR/EV – MOTOEVAPORATING UNITS
COOLING CAPACITY AND COMPRESSORS INPUT POWER**

Mod.	TWUC (°C)	PF (kW)						PA (kW)					
		TC (°C)						TC (°C)					
		30	35	40	45	50	55	30	35	40	45	50	55
060	5	68,3	64,8	61,2	57,5	53,8	49,9	11,7	13,0	14,6	16,4	18,4	20,7
	7	73,7	70,0	66,2	62,2	58,2	54,1	11,7	13,0	14,6	16,4	18,4	20,7
	9	79,4	75,4	71,4	67,2	62,9	58,6	11,8	13,0	14,6	16,4	18,4	20,8
	11	85,4	81,2	76,9	72,5	68,0	63,3	11,9	13,1	14,6	16,4	18,4	20,8
	13	91,8	87,4	82,8	78,1	73,3	68,4	12,0	13,2	14,6	16,4	18,4	20,8
	15	98,6	93,9	89,0	84,0	78,9	73,7	12,2	13,3	14,7	16,4	18,4	20,7

Mod.	TWUC (°C)	PF (kW)						PA (kW)					
		TC (°C)						TC (°C)					
		30	35	40	45	50	55	30	35	40	45	50	55
070	5	75,4	71,5	67,5	63,4	59,2	54,9	13,1	14,5	16,2	18,2	20,5	23,0
	7	81,3	77,2	73,0	68,6	64,1	59,6	13,2	14,6	16,2	18,2	20,5	23,1
	9	87,6	83,2	78,7	74,1	69,3	64,5	13,4	14,7	16,3	18,2	20,5	23,1
	11	94,3	89,6	84,8	79,9	74,9	69,7	13,5	14,8	16,3	18,3	20,5	23,1
	13	101,4	96,4	91,3	86,1	80,7	75,3	13,7	14,9	16,4	18,3	20,5	23,1
	15	108,8	103,5	98,2	92,6	86,9	81,1	13,9	15,1	16,5	18,4	20,6	23,2

Mod.	TWUC (°C)	PF (kW)						PA (kW)					
		TC (°C)						TC (°C)					
		30	35	40	45	50	55	30	35	40	45	50	55
080	5	91,7	87,1	82,3	77,4	72,4	67,3	15,7	17,3	19,4	21,8	24,7	27,9
	7	98,9	94,0	88,9	83,8	78,4	72,9	16,0	17,4	19,4	21,8	24,6	27,9
	9	106,6	101,4	96,0	90,5	84,8	78,9	16,3	17,6	19,4	21,8	24,6	27,8
	11	114,7	109,1	103,4	97,6	91,5	85,3	16,7	17,8	19,5	21,8	24,5	27,8
	13	123,3	117,4	111,3	105,1	98,7	92,1	17,2	18,2	19,7	21,8	24,5	27,7
	15	132,4	126,1	119,7	113,1	106,3	99,3	17,9	18,6	20,0	22,0	24,5	27,7

Mod.	TWUC (°C)	PF (kW)						PA (kW)					
		TC (°C)						TC (°C)					
		30	35	40	45	50	55	30	35	40	45	50	55
090	5	106,9	101,5	95,9	90,0	84,0	77,7	18,2	20,2	22,5	25,3	28,4	32,0
	7	115,3	109,6	103,7	97,5	91,0	84,4	18,3	20,3	22,6	25,3	28,5	32,1
	9	124,2	118,2	111,9	105,4	98,5	91,5	18,4	20,4	22,7	25,4	28,5	32,1
	11	133,7	127,3	120,6	113,7	106,5	99,0	18,6	20,5	22,7	25,4	28,6	32,2
	13	143,7	136,9	129,9	122,5	114,9	107,0	18,8	20,6	22,9	25,5	28,6	32,2
	15	154,2	147,0	139,6	131,9	123,8	115,5	19,0	20,8	23,0	25,6	28,7	32,3

Mod.	TWUC (°C)	PF (kW)						PA (kW)					
		TC (°C)						TC (°C)					
		30	35	40	45	50	55	30	35	40	45	50	55
110	5	122,1	115,9	109,5	102,7	95,5	88,1	20,6	23,0	25,7	28,7	32,2	36,1
	7	131,7	125,2	118,4	111,2	103,7	95,8	20,6	23,1	25,8	28,8	32,3	36,3
	9	141,9	135,0	127,8	120,2	112,3	104,0	20,6	23,1	25,9	29,0	32,4	36,4
	11	152,6	145,4	137,8	129,8	121,5	112,7	20,5	23,1	26,0	29,1	32,6	36,5
	13	164,0	156,4	148,4	140,0	131,2	121,9	20,3	23,1	26,0	29,2	32,7	36,7
	15	176,0	168,0	159,5	150,7	141,4	131,7	20,1	23,0	26,0	29,3	32,9	36,9

TWUC: Evaporator outlet water temperature (°C) (Dt=5°C)
 TC: Condensing temperature (°C)
 PA: Compressors input power (Kw)
 PF: Cooling capacity (Kw)

**WDR/EV – MOTOEVAPORATING UNITS
COOLING CAPACITY AND COMPRESSORS INPUT POWER**

Mod.	TWUC (°C)	PF (kW)						PA (kW)					
		TC (°C)						TC(°C)					
		30	35	40	45	50	55	30	35	40	45	50	55
120	5	139,0	131,4	123,5	115,3	106,9	98,2	23,5	26,0	28,9	32,2	36,1	40,6
	7	150,2	142,1	133,7	125,1	116,2	107,0	23,6	26,2	29,0	32,4	36,2	40,7
	9	162,1	153,5	144,6	135,5	126,0	116,3	23,7	26,3	29,2	32,5	36,3	40,8
	11	174,6	165,5	156,1	146,4	136,5	126,2	23,8	26,4	29,3	32,7	36,5	40,9
	13	187,9	178,3	168,3	158,1	147,5	136,7	23,9	26,5	29,5	32,8	36,6	41,0
	15	201,9	191,7	181,2	170,4	159,3	147,8	24,0	26,6	29,6	33,0	36,8	41,2

Mod.	TWUC (°C)	PF (kW)						PA (kW)					
		TC (°C)						TC(°C)					
		30	35	40	45	50	55	30	35	40	45	50	55
130	5	155,9	146,8	137,5	127,9	118,2	108,3	26,4	29,0	32,1	35,7	40,0	45,1
	7	168,7	159,0	149,1	139,0	128,6	118,1	26,6	29,2	32,3	35,9	40,1	45,1
	9	182,2	171,9	161,4	150,7	139,7	128,6	26,9	29,5	32,5	36,0	40,3	45,2
	11	196,6	185,6	174,5	163,1	151,5	139,6	27,2	29,7	32,7	36,2	40,4	45,2
	13	211,7	200,1	188,3	176,2	163,9	151,4	27,5	30,0	32,9	36,4	40,5	45,3
	15	227,7	215,4	202,9	190,1	177,1	163,8	27,8	30,3	33,2	36,7	40,7	45,5

Mod.	TWUC (°C)	PF (kW)						PA (kW)					
		TC (°C)						TC(°C)					
		30	35	40	45	50	55	30	35	40	45	50	55
152	5	173,2	163,7	154,0	143,8	133,2	122,0	28,7	31,7	35,2	39,2	43,9	49,3
	7	187,6	177,4	167,0	156,3	145,1	133,2	29,0	31,9	35,4	39,4	44,0	49,4
	9	202,9	192,0	180,9	169,5	157,6	145,1	29,3	32,2	35,6	39,5	44,1	49,5
	11	219,2	207,5	195,6	183,5	170,9	157,8	29,7	32,5	35,8	39,7	44,3	49,6
	13	236,6	224,0	211,3	198,4	185,0	171,2	30,1	32,8	36,1	39,9	44,4	49,7
	15	255,1	241,6	228,0	214,2	200,0	185,4	30,5	33,2	36,4	40,2	44,6	49,8

Mod.	TWUC (°C)	PF (kW)						PA (kW)					
		TC (°C)						TC(°C)					
		30	35	40	45	50	55	30	35	40	45	50	55
162	5	190,5	180,6	170,5	159,8	148,2	135,6	31,0	34,4	38,3	42,7	47,8	53,6
	7	206,5	195,8	184,9	173,6	161,5	148,3	31,4	34,6	38,4	42,8	47,9	53,7
	9	223,6	212,0	200,4	188,3	175,5	161,7	31,7	34,9	38,7	43,0	48,0	53,8
	11	241,9	229,4	216,8	203,9	190,4	175,9	32,2	35,3	38,9	43,2	48,2	53,9
	13	261,5	247,9	234,4	220,6	206,2	191,0	32,7	35,7	39,2	43,4	48,3	54,1
	15	282,4	267,7	253,1	238,3	223,0	206,9	33,3	36,1	39,6	43,7	48,5	54,2

Mod.	TWUC (°C)	PF (kW)						PA (kW)					
		TC (°C)						TC(°C)					
		30	35	40	45	50	55	30	35	40	45	50	55
144	5	167,0	158,5	149,8	140,9	131,6	122,2	28,9	31,9	35,6	40,0	45,2	50,9
	7	180,2	171,2	161,9	152,4	142,6	132,5	29,2	32,0	35,6	40,0	45,1	50,9
	9	194,2	184,6	174,7	164,6	154,1	143,4	29,6	32,2	35,7	40,0	45,1	50,9
	11	209,0	198,8	188,3	177,5	166,4	155,0	30,2	32,6	35,9	40,0	45,1	50,9
	13	224,6	213,8	202,6	191,2	179,4	167,4	31,0	33,0	36,1	40,1	45,1	50,9
	15	241,2	229,6	217,8	205,7	193,2	180,5	31,9	33,7	36,5	40,3	45,1	50,8

Mod.	TWUC (°C)	PF (kW)						PA (kW)					
		TC (°C)						TC(°C)					
		30	35	40	45	50	55	30	35	40	45	50	55
164	5	183,3	174,1	164,6	154,9	144,8	134,5	31,5	34,6	38,7	43,7	49,4	55,8
	7	197,8	188,0	177,9	167,5	156,8	145,9	31,9	34,8	38,7	43,6	49,3	55,8
	9	213,2	202,7	192,0	180,9	169,6	157,9	32,6	35,1	38,8	43,5	49,2	55,7
	11	229,4	218,3	206,9	195,1	183,1	170,7	33,4	35,6	39,0	43,5	49,1	55,5
	13	246,6	234,8	222,7	210,2	197,4	184,3	34,5	36,3	39,4	43,7	49,0	55,4
	15	264,7	252,2	239,3	226,1	212,6	198,6	35,9	37,2	39,9	43,9	49,1	55,4

TWUC: Evaporator outlet water temperature (°C) (Dt=5°C)
 TC: Condensing temperature (°C)
 PA: Compressors input power (Kw)
 PF: Cooling capacity (Kw)

**WDR/EV – MOTOEVAPORATING UNITS
COOLING CAPACITY AND COMPRESSORS INPUT POWER**

Mod.	TWUC (°C)	PF (kW)						PA (kW)					
		TC (°C)						TC(°C)					
		30	35	40	45	50	55	30	35	40	45	50	55
190	5	213,7	203,0	191,8	180,1	167,9	155,3	36,4	40,4	45,1	50,5	56,9	64,0
	7	230,6	219,2	207,3	194,9	182,1	168,7	36,6	40,5	45,2	50,6	56,9	64,1
	9	248,5	236,4	223,8	210,7	197,1	183,0	36,8	40,7	45,3	50,7	57,0	64,2
	11	267,3	254,6	241,3	227,4	213,0	198,1	37,2	40,9	45,5	50,9	57,1	64,3
	13	287,3	273,8	259,7	245,1	229,9	214,1	37,6	41,3	45,7	51,0	57,2	64,4
	15	308,4	294,1	279,2	263,7	247,7	231,0	38,1	41,6	46,0	51,2	57,4	64,6

Mod.	TWUC (°C)	PF (kW)						PA (kW)					
		TC (°C)						TC(°C)					
		30	35	40	45	50	55	30	35	40	45	50	55
210	5	244,1	231,8	218,9	205,3	191,0	176,1	41,2	46,1	51,4	57,4	64,3	72,3
	7	263,4	250,4	236,7	222,4	207,3	191,6	41,2	46,2	51,6	57,7	64,6	72,5
	9	283,7	270,1	255,6	240,5	224,6	208,0	41,1	46,3	51,8	57,9	64,9	72,8
	11	305,3	290,8	275,6	259,6	242,9	225,4	40,9	46,3	51,9	58,2	65,2	73,1
	13	328,0	312,8	296,8	279,9	262,3	243,9	40,7	46,2	52,0	58,4	65,4	73,4
	15	352,0	336,0	319,1	301,4	282,8	263,4	40,3	46,0	52,1	58,5	65,7	73,7

Mod.	TWUC (°C)	PF (kW)						PA (kW)					
		TC (°C)						TC(°C)					
		30	35	40	45	50	55	30	35	40	45	50	55
240	5	278,0	262,7	246,9	230,6	213,7	196,4	47,0	52,0	57,8	64,4	72,2	81,2
	7	300,4	284,2	267,5	250,1	232,3	213,9	47,3	52,3	58,1	64,7	72,4	81,4
	9	324,1	307,0	289,2	270,9	252,0	232,6	47,5	52,6	58,4	65,0	72,7	81,6
	11	349,2	331,1	312,3	292,9	272,9	252,3	47,7	52,9	58,7	65,3	73,0	81,8
	13	375,7	356,5	336,7	316,2	295,1	273,3	47,8	53,1	59,0	65,6	73,3	82,1
	15	403,7	383,4	362,4	340,8	318,5	295,6	47,9	53,3	59,2	65,9	73,6	82,3

Mod.	TWUC (°C)	PF (kW)						PA (kW)					
		TC (°C)						TC(°C)					
		30	35	40	45	50	55	30	35	40	45	50	55
260	5	311,9	293,6	274,9	255,9	236,4	216,7	52,8	58,0	64,2	71,5	80,1	90,1
	7	337,4	318,0	298,2	277,9	257,3	236,3	53,3	58,4	64,5	71,8	80,3	90,2
	9	364,5	343,9	322,8	301,3	279,4	257,1	53,8	58,9	65,0	72,1	80,5	90,3
	11	393,1	371,3	348,9	326,1	302,9	279,2	54,4	59,4	65,4	72,5	80,8	90,5
	13	423,4	400,2	376,6	352,4	327,8	302,7	55,0	60,0	65,9	72,9	81,1	90,7
	15	455,4	430,9	405,8	380,3	354,2	327,7	55,6	60,6	66,4	73,3	81,5	90,9

Mod.	TWUC (°C)	PF (kW)						PA (kW)					
		TC (°C)						TC(°C)					
		30	35	40	45	50	55	30	35	40	45	50	55
300	5	346,4	327,4	307,9	287,7	266,5	244,0	57,4	63,4	70,3	78,4	87,8	98,7
	7	375,2	354,8	334,0	312,5	290,1	266,5	58,0	63,9	70,7	78,7	88,0	98,8
	9	405,8	384,0	361,8	338,9	315,2	290,3	58,7	64,4	71,1	79,1	88,3	99,0
	11	438,5	415,0	391,3	367,0	341,8	315,6	59,4	65,0	71,6	79,4	88,6	99,2
	13	473,2	448,1	422,7	396,8	370,1	342,3	60,2	65,7	72,2	79,9	88,9	99,4
	15	510,1	483,2	456,0	428,4	400,1	370,8	61,1	66,4	72,8	80,3	89,3	99,7

Mod.	TWUC (°C)	PF (kW)						PA (kW)					
		TC (°C)						TC(°C)					
		30	35	40	45	50	55	30	35	40	45	50	55
320	5	380,9	361,2	340,9	319,5	296,5	271,3	62,0	68,8	76,5	85,4	95,6	107,2
	7	413,0	391,6	369,9	347,2	322,9	296,7	62,7	69,3	76,9	85,7	95,8	107,4
	9	447,2	424,1	400,7	376,5	351,0	323,5	63,5	69,9	77,3	86,0	96,1	107,7
	11	483,8	458,8	433,6	407,8	380,7	351,9	64,4	70,6	77,8	86,4	96,4	107,9
	13	523,0	495,9	468,8	441,1	412,4	382,0	65,4	71,3	78,4	86,8	96,7	108,1
	15	564,9	535,5	506,2	476,6	446,0	413,9	66,6	72,3	79,1	87,4	97,1	108,4

TWUC: Evaporator outlet water temperature (°C) (Dt=5°C)
 TC: Condensing temperature (°C)
 PA: Compressors input power (Kw)
 PF: Cooling capacity (Kw)

CONDENSER WATER PRESSURE DROPS

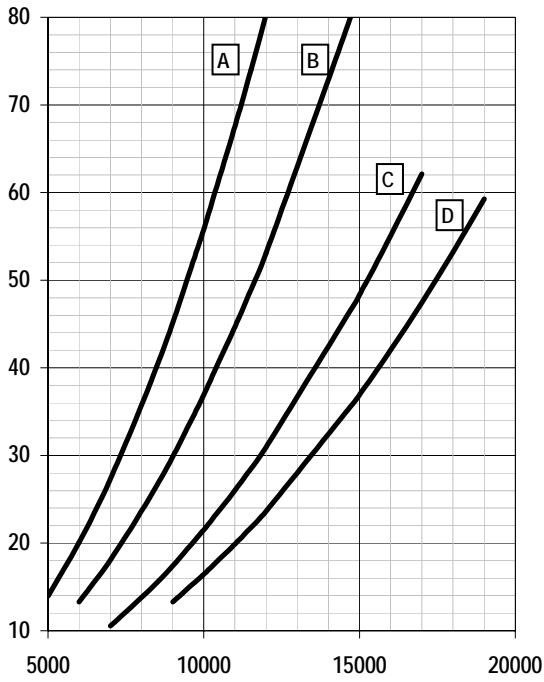

A: WDR039-045 B: WDR050
C: WDR 060-070 D: WDR 080

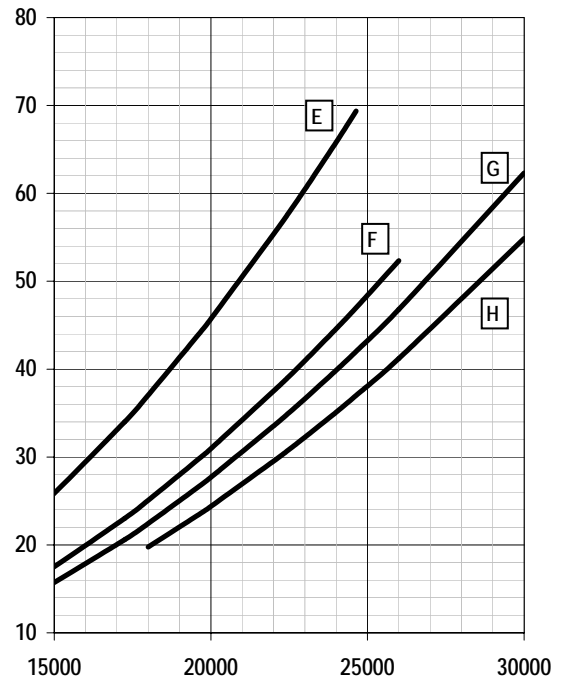

E: WDR090 F: WDR110
G: WDR120 H: WDR130

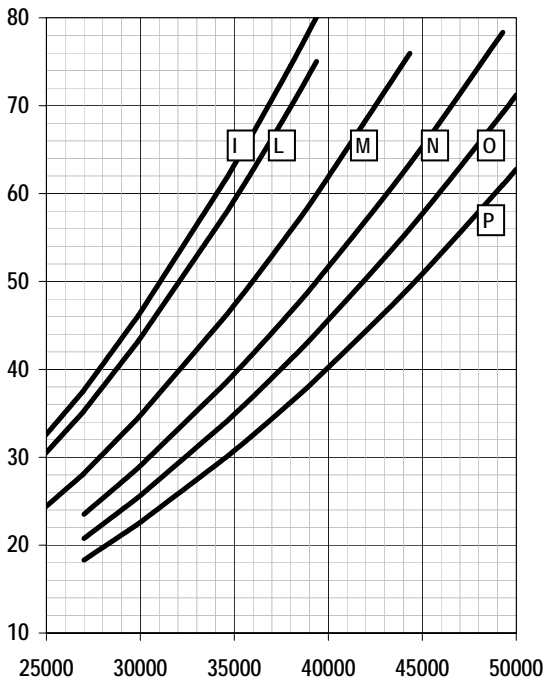

I: WDR152-144 L: WDR162-164
M: WDR 190 N: WDR 210
O: WDR240 P: WDR260

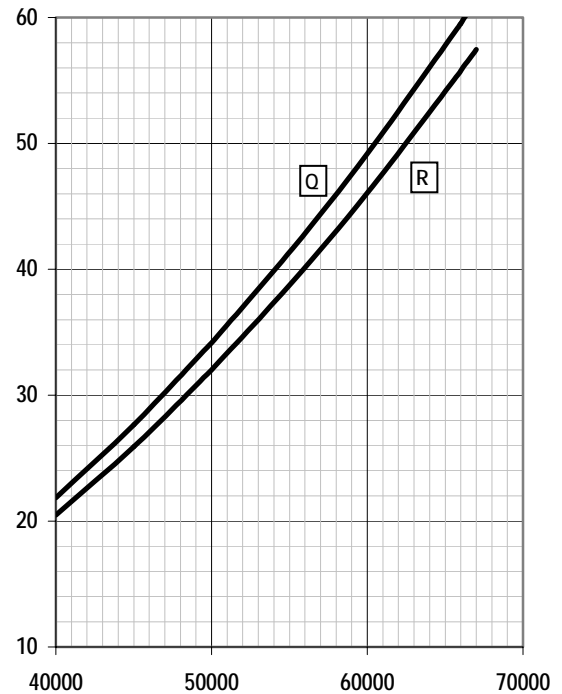

Q: WDR300
R: WDR320

EVAPORATOR WATER PRESSURE DROPS

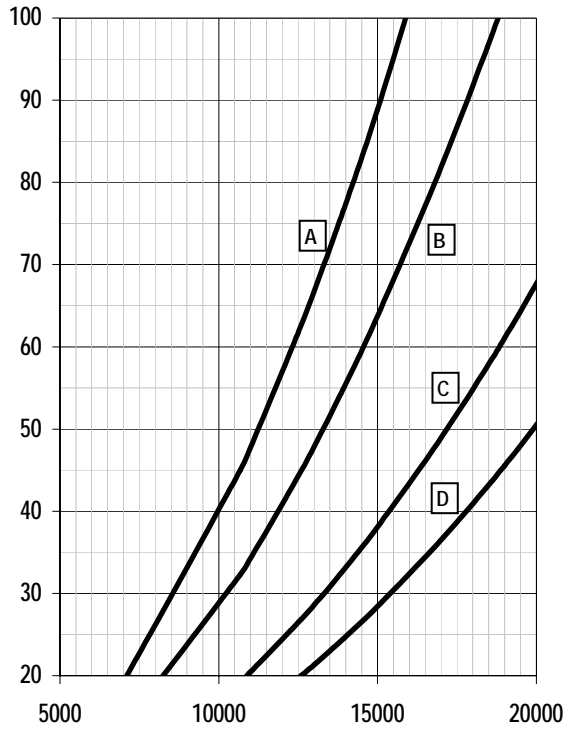

A: WDR039-045 B: WDR050
C: WDR060-070 D: WDR080

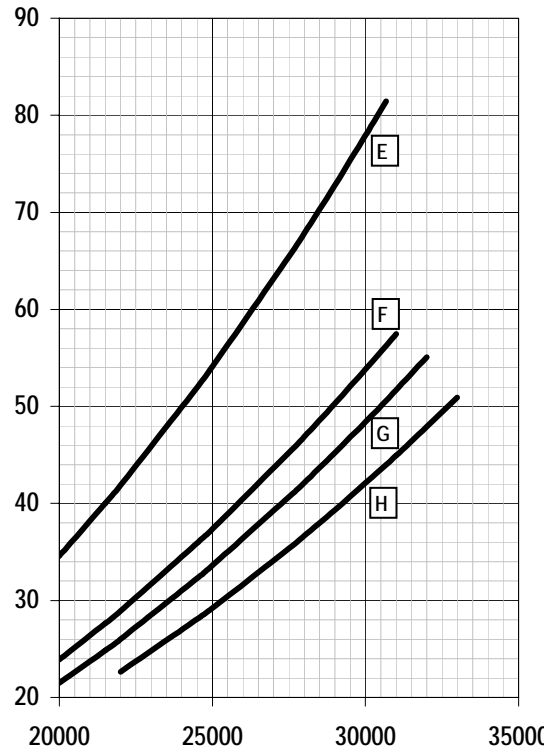

E: WDR090 F: WDR110
G: WDR120 H: WDR130

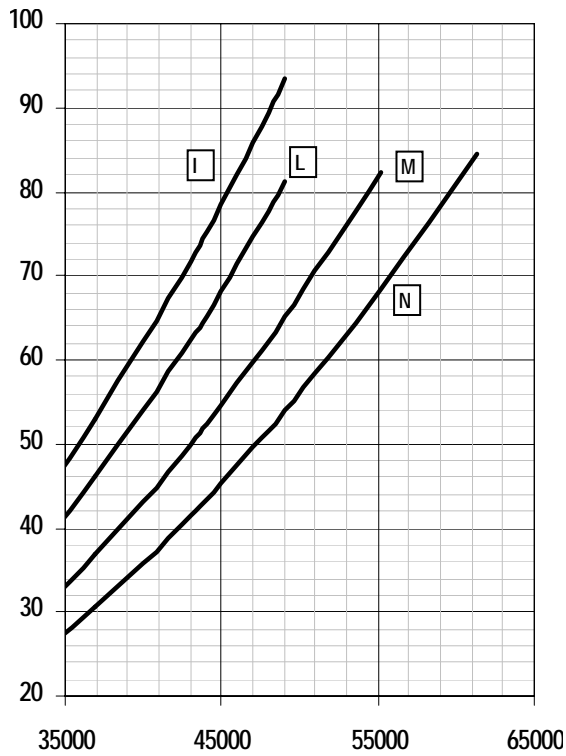

I: WDR152-144 L: WDR162-164
M: WDR190 N: WDR210

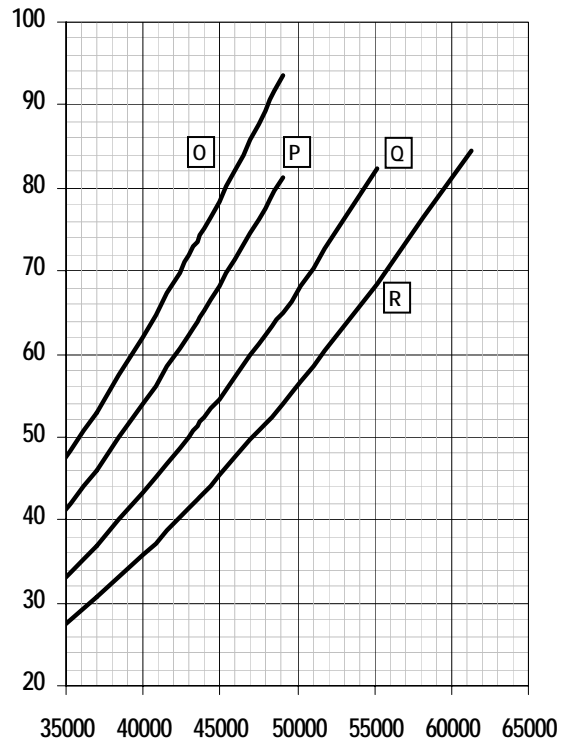

O: WDR240 P: WDR260
Q: WDR300 R: WDR320

REFRIGERANT LAYOUTS

- BTI Return water sensor
- BTO Supply water sensor
- CH Charging plug
- CN Condenser
- DSP Partial recovery heat exchanger
- EV Evaporator
- EXV Thermostatic valve
- FL Refrigerant filter
- IO Equalizer with sight glass
- IV Sight glass
- MC Compressor
- SFW Flow switch
- SHP High pressure switch
- SLP Low pressure switch
- SV Manual valve
- VSH High pressure safety valve
- YL Liquid line solenoid valve

WDR – WATER CHILLER STANDARD CONFIGURATION

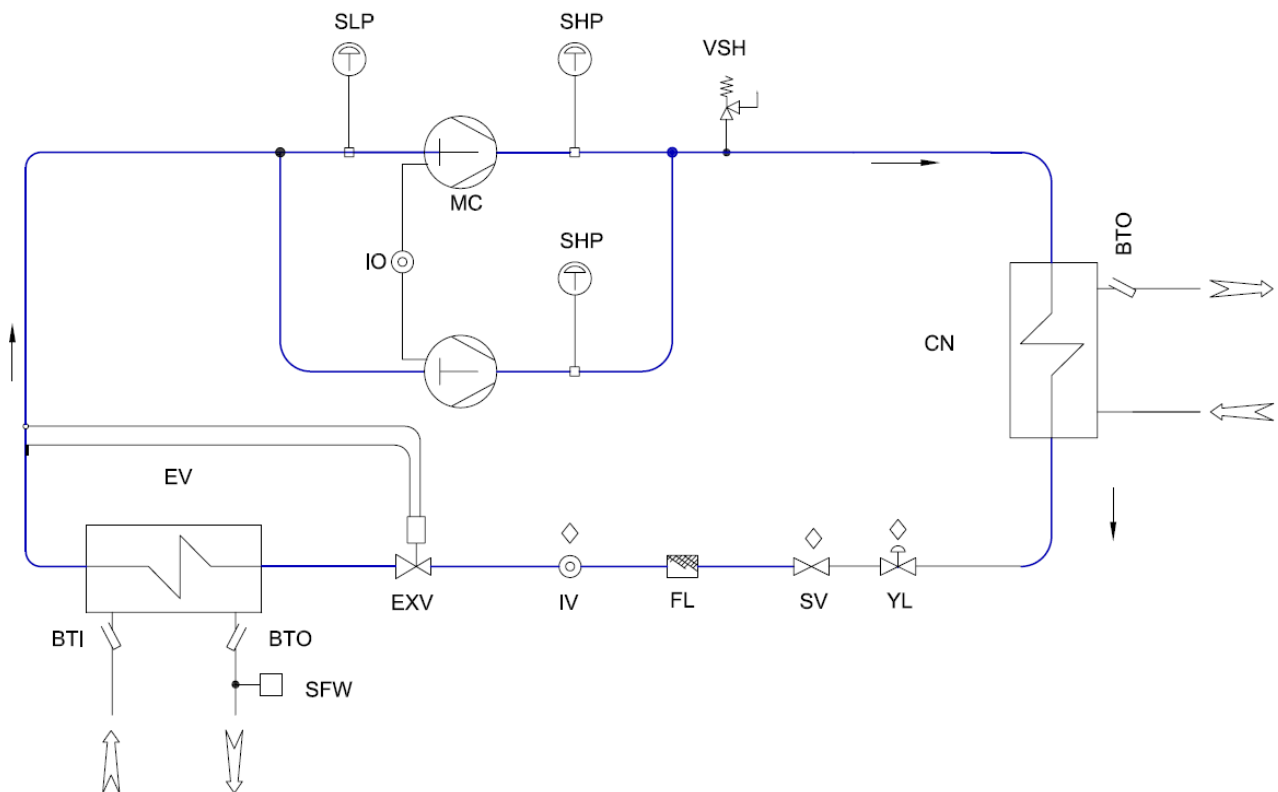

WDR/EV - MOTOEVAPORATING VERSION

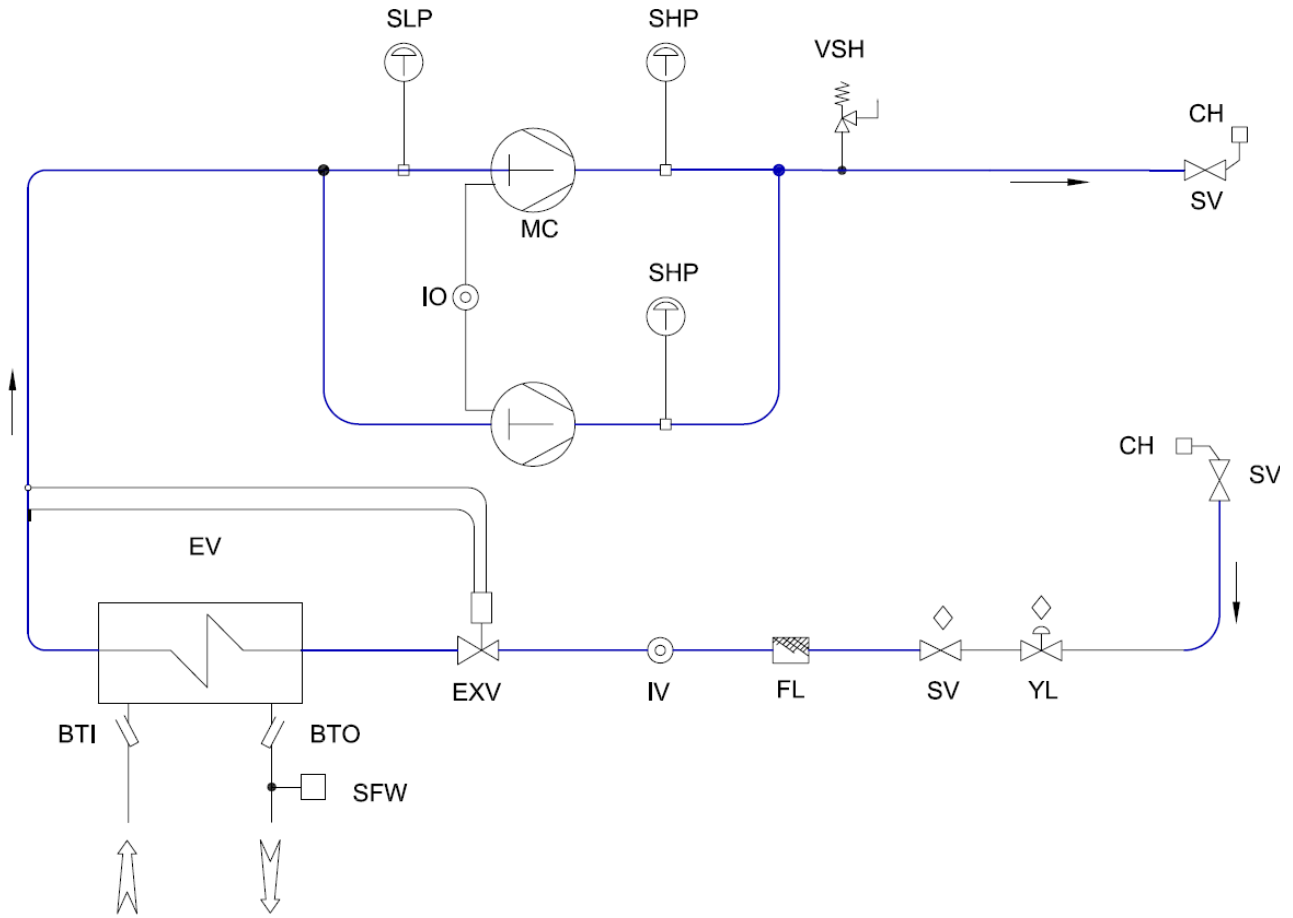

WDR/RP - WATER CHILLER WITH PARTIAL HEAT RECOVERY

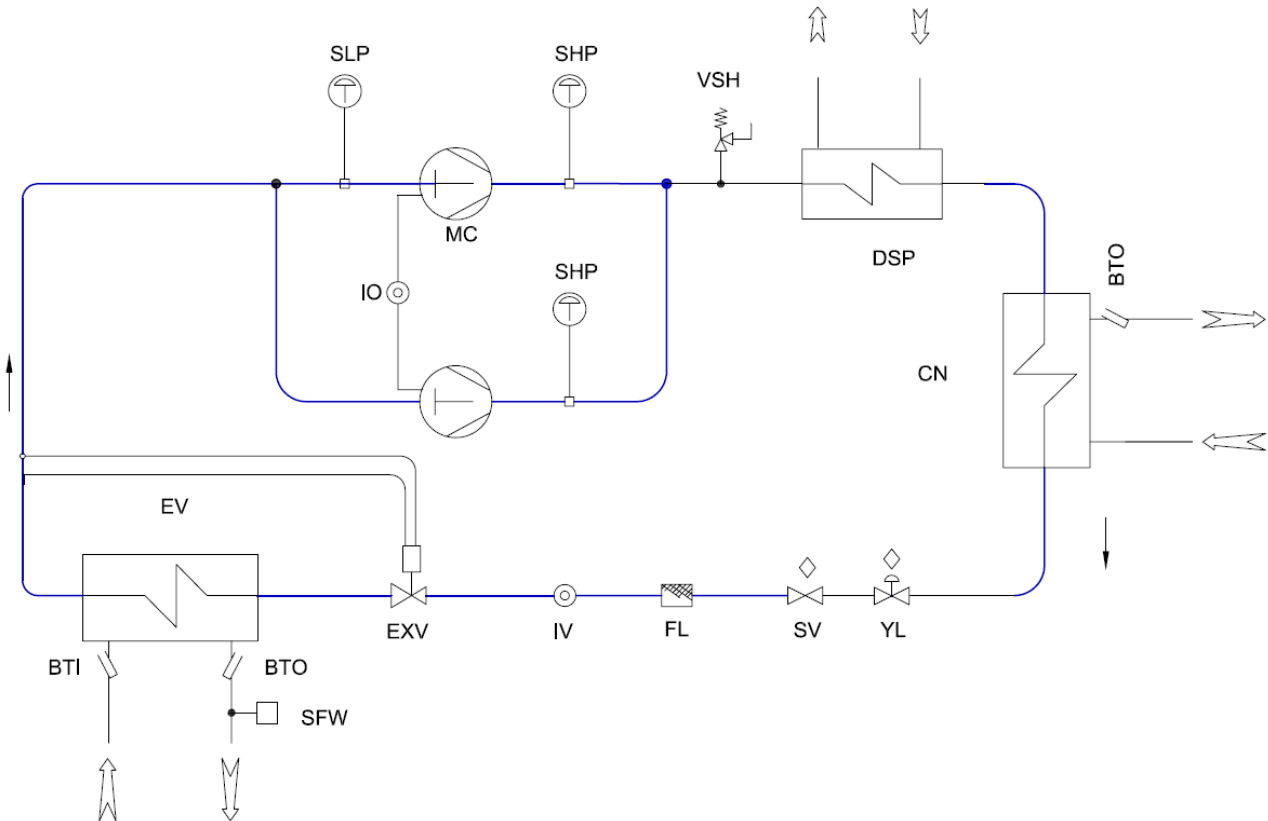

PARTIAL HEAT RECOVERY CAPACITY (OPTION)

Mod.		039	045	050	060	070	080	090	110
Partial heat recovery nominal capacity	kW	9,5	12,8	13,0	15,0	15,3	18,5	21,5	24,8
Water flow	l/h	1635	2200	2240	2580	2630	3190	3700	4270
Water pressure drops	kPa	10	14	11	15	16	18	11	15
Mod.		120	130	140	160	190	210	240	260
Partial heat recovery nominal capacity	kW	27,5	30,0	34,0	37,0	43,0	49,0	55,0	61,5
Water flow	l/h	4730	5160	5850	6360	7400	8430	9460	10570
Water pressure drops	kPa	13	18	18	25	11	15	19	25
Mod.		300	320						
Partial heat recovery nominal capacity	kW	69,0	76,0						
Water flow	l/h	11850	13000						
Water pressure drops	kPa	20	25						

The nominal value refers to a condenser water temperature 40/45°C and heat recovery water outlet temperature of 50°C (Dt 5°C).

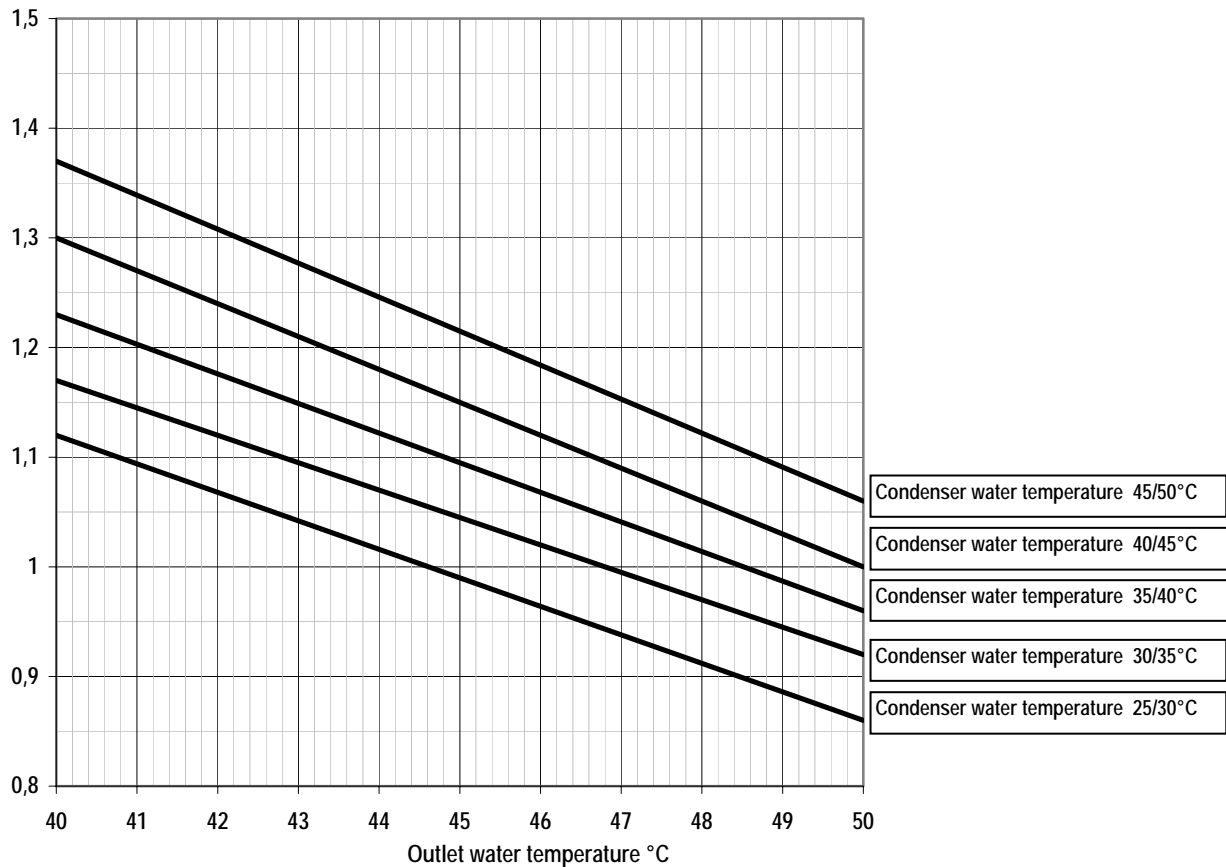

The heat recovery capacity in different conditions can be obtained multiplying the nominal capacity (See above), by the correction factor indicated in the table.

WATER PUMPS AVAILABLE STATIC PRESSURE (OPTION)

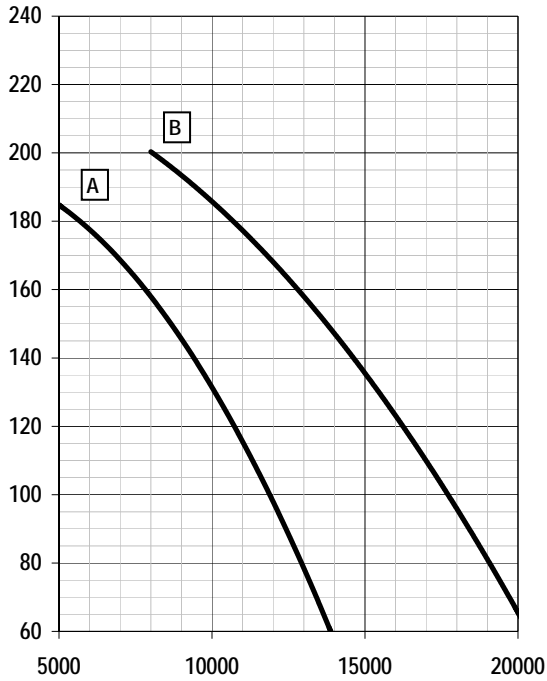

A: WDR039,045,050,060,070
B: WDR080, 090

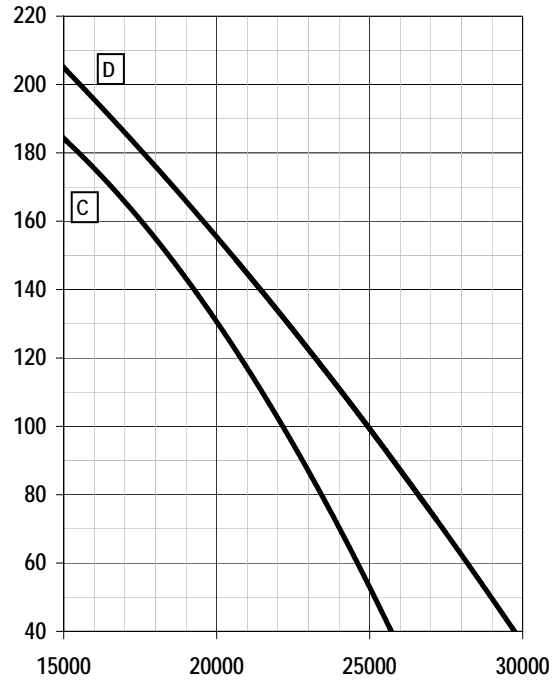

C: WDR110, 120
D: WDR130, 152, 144

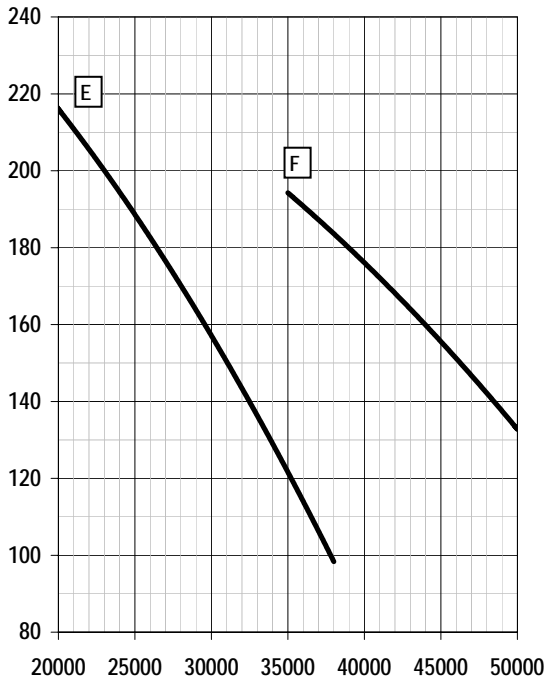

E: WDR162,164,190,210
F: WDR 240, 260

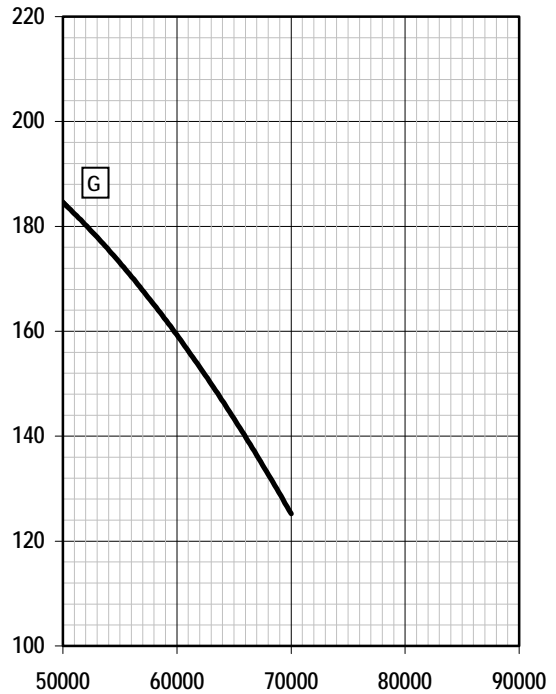

G: WDR300, 320

OPERATION LIMITS

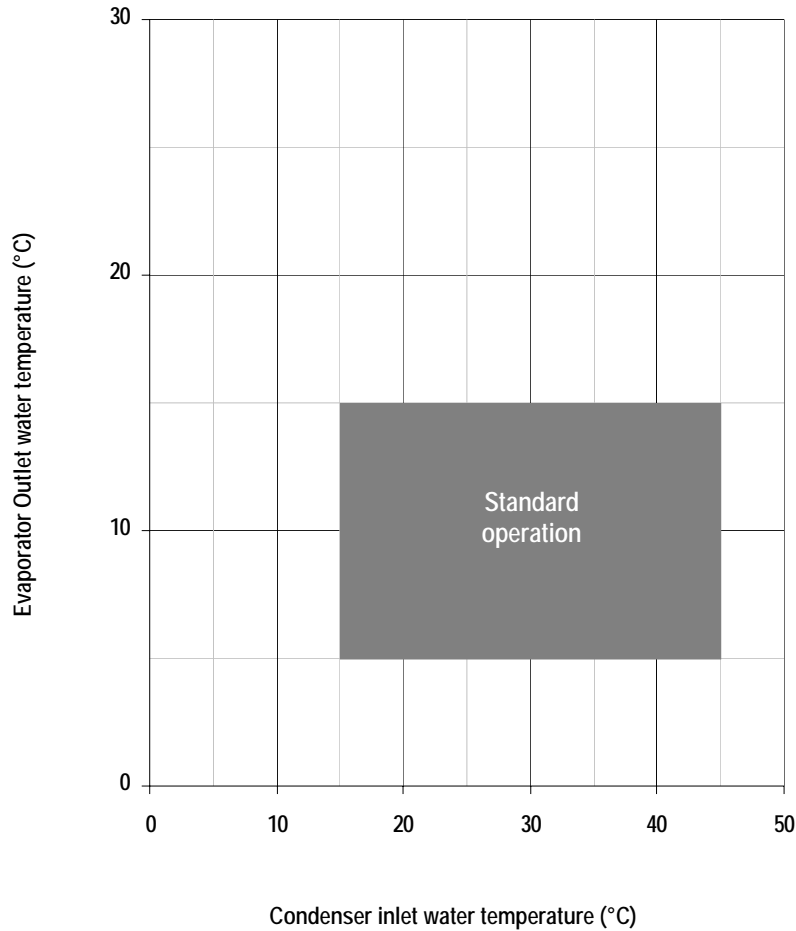

Heat exchangers water flow rate

The nominal water flow rate given by HIDROS is referred to a Dt of 5 °C. Maximum flow rate allowed is the one that presents a Dt of 3°C: higher values may cause too high pressure drop. The minimum water flow rate allowed is the one presenting a Dt of 8 °C. Insufficient values cause too low evaporating temperatures with the action of safety devices which would stop the unit.

Evaporator water temperature (summer operation)

The minimum evaporator water outlet is 5 °C. The maximum evaporator water outlet is 15°C. In case of operation outside this range of temperatures please contact the company.

Condenser water temperature (summer operation)

The minimum condenser water inlet is 15 °C. The maximum condenser water inlet is 45°C.



WARNING: In case of operation outside this range of temperatures please contact our technical department.

COMPRESSORS CAPACITY STEP CONTROLS

COMPRESSORS NUMBER				
Model	1	2	3	4
039	50%	50%	---	---
045	50%	50%	---	---
050	50%	50%	---	---
060	44%	56%	---	---
070	50%	50%	---	---
080	50%	50%	---	---
090	43%	57%	---	---
110	50%	50%	---	---
120	45%	55%	---	---
130	50%	50%	---	---
152	44%	56%	---	---
162	50%	50%	---	---
144	21,5%	21,5%	28,5%	28,5%
164	25%	25%	25%	25%
190	21,5%	21,5%	28,5%	28,5%
210	25%	25%	25%	25%
240	22,5%	22,5%	27,5%	27,5%
260	25%	25%	25%	25%
300	22%	22%	28%	28%
320	25%	25%	25%	25%

CORRECTION TABLES Source side heat exchanger temperature difference °C

Fouling factor	3	5	8	10
HCCCP	1,02	1	0,98	0,97
IPCF	1,01	1	0,99	0,98

CORRECTION TABLES User side heat exchanger temperature difference °C

Fouling factor	3	5	8	10
HCCCP	0,99	1	1,01	1,015
IPCF	1,01	1	0,99	0,99

HCCF = Heating capacity correction factor. IPCF = Input power correction factor.

The correction factors have to be applied to the nominal data reported in the previous tables that shows the capacities with Δt_5 °C.

CORRECTION TABLES Operation with glycol

Glicol percentage	Freezing point (°C)	CCF	IPCF	WFCF	PDCF
10	-3,2	0,985	1	1,02	1,08
20	-7,8	0,98	0,99	1,05	1,12
30	-14,1	0,97	0,98	1,09	1,22
40	-22,3	0,965	0,97	1,14	1,25
50	-33,8	0,955	0,965	1,2	1,33

CCF: Capacity correction factor

IPCF: Input power correction factor

WFCF: Water flow correction factor

PDCF: Pressure drops correction factor.

The water flow rate and pressure drop correction factors are to be applied directly to the values given for operation without glycol. The water flow rate correction factor is calculated in order to maintain the same temperature difference as that which would be obtained without glycol. The pressure drop correction factor takes into account the different flow rate obtained from the application of the flow rate correction factor.

CORRECTION TABLES Different Fouling factors

Fouling factor	0,00005	0,0001	0,0002
CCCP	1	0,98	0,94
IPCF	1	0,98	0,95

CCF = Cooling capacity correction factor.

IPCF = Input power correction factor.

SOUND DATA

SOUND LEVELS STANDARD VERSIONS											
Mod.	Octave bands (Hz)								Lw		Lp
	63 dB	125 dB	250 dB	500 dB	1K dB	2K dB	4K dB	8K dB	dB	dB(A)	dB(A)
039	93,1	84,3	78,2	76,7	75,6	70,2	66,8	57,7	93,9	80	52
045	93,1	84,3	78,2	76,7	75,6	70,2	66,8	57,7	93,9	80	52
050	94,1	85,3	79,2	77,7	76,6	71,2	67,8	58,7	94,9	81	53
060	95,1	86,3	80,2	78,7	77,6	72,2	68,8	59,7	95,9	82	54
070	95,1	86,3	80,2	78,7	77,6	72,2	68,8	59,7	95,9	82	54
080	96,1	87,3	81,2	79,7	78,6	73,2	69,8	60,7	96,9	83	55
090	96,1	87,3	81,2	79,7	78,6	73,2	69,8	60,7	96,9	83	55
110	97,1	88,3	82,2	80,7	79,6	74,2	70,8	61,7	97,9	84	56
120	97,1	88,3	82,2	80,7	79,6	74,2	70,8	61,7	97,9	84	56
130	98,1	89,3	83,2	81,7	80,6	75,2	71,8	62,7	98,9	85	57
152	98,1	89,3	83,2	81,7	80,6	75,2	71,8	62,7	98,9	85	57
162	98,1	89,3	83,2	81,7	80,6	75,2	71,8	62,7	98,9	85	57
144	98,1	89,3	83,2	81,7	80,6	75,2	71,8	62,7	98,9	85	57
164	98,1	89,3	83,2	81,7	80,6	75,2	71,8	62,7	98,9	85	57
190	99,1	90,3	84,2	82,7	81,6	76,2	72,8	63,7	99,9	86	58
210	101,1	92,3	86,2	84,7	83,6	78,2	74,8	65,7	101,9	88	60
240	101,1	92,3	86,2	84,7	83,6	78,2	74,8	65,7	101,9	88	60
260	101,1	92,3	86,2	84,7	83,6	78,2	74,8	65,7	101,9	88	60
300	103,1	94,3	88,2	86,7	85,6	80,2	76,8	67,7	103,9	90	62
320	103,1	94,3	88,2	86,7	85,6	80,2	76,8	67,7	103,9	90	62

SOUND LEVELS (LS) LOW NOISE VERSIONS											
Mod.	Octave bands (Hz)								Lw		Lp
	63 dB	125 dB	250 dB	500 dB	1K dB	2K dB	4K dB	8K dB	dB	dB(A)	dB(A)
039/LS	87,1	78,3	72,2	70,7	69,6	64,2	60,8	51,7	87,9	74	46
045/LS	87,1	78,3	72,2	70,7	69,6	64,2	60,8	51,7	87,9	74	46
050/LS	88,1	79,3	73,2	71,7	70,6	65,2	61,8	52,7	88,9	75	47
060/LS	89,1	80,3	74,2	72,7	71,6	66,2	62,8	53,7	89,9	76	48
070/LS	89,1	80,3	74,2	72,7	71,6	66,2	62,8	53,7	89,9	76	48
080/LS	90,1	81,3	75,2	73,7	72,6	67,2	63,8	54,7	90,9	77	49
090/LS	90,1	81,3	75,2	73,7	72,6	67,2	63,8	54,7	90,9	77	49
110/LS	91,1	82,3	76,2	74,7	73,6	68,2	64,8	55,7	91,9	78	50
120/LS	91,1	82,3	76,2	74,7	73,6	68,2	64,8	55,7	91,9	78	50
130/LS	92,1	83,3	77,2	75,7	74,6	69,2	65,8	56,7	92,9	79	51
152/LS	92,1	83,3	77,2	75,7	74,6	69,2	65,8	56,7	92,9	79	51
162/LS	92,1	83,3	77,2	75,7	74,6	69,2	65,8	56,7	92,9	79	51
144/LS	92,1	83,3	77,2	75,7	74,6	69,2	65,8	56,7	92,9	79	51
164/LS	92,1	83,3	77,2	75,7	74,6	69,2	65,8	56,7	92,9	79	51
190/LS	93,1	84,3	78,2	76,7	75,6	70,2	66,8	57,7	93,9	80	52
210/LS	95,1	86,3	80,2	78,7	77,6	72,2	68,8	59,7	95,9	82	54
240/LS	95,1	86,3	80,2	78,7	77,6	72,2	68,8	59,7	95,9	82	54
260/LS	95,1	86,3	80,2	78,7	77,6	72,2	68,8	59,7	95,9	82	54
300/LS	97,1	88,3	82,2	80,7	79,6	74,2	70,8	61,7	97,9	84	56
320/LS	97,1	88,3	82,2	80,7	79,6	74,2	70,8	61,7	97,9	84	56

Lw: Sound power level according to ISO 3746.

Lp: Sound pressure level measured at 10 mt from the unit in free field conditions direction factor Q=2 according to ISO 3746.

SAFETY DEVICE SETTING

Device		Capacity Steps		Capacity steps		Reset Type
		2		4		
		Set-point	Differential	Set point	Differential	
Control thermostat (summer)	°C	10	2	9	3	...
Anti-freeze thermostat	°C	4	6	4	6	MANUAL
Electric heater thermostat	°C	4	6	4	6	MANUAL
High pressure switch	Bar	28	7	28	7	MANUAL
Low pressure switch	Bar	0,7	1	0,7	1	MANUAL
Water safety valve (Optional)	Bar	6	...	6

ELECTRIC DATA

Power supply	V/-/Hz	400 / 3 / 50		Control board	V/-/Hz	24 / 1 / 50
Auxiliary circuit	V/-/Hz	230 / 1 / 50				

Electric data may change for updating. It is therefore necessary to refer always to the wiring diagram inside the units.



WARNING: All this operation described in next chapters MUST BE DONE BY TRAINED PEOPLE ONLY. Before every operation of servicing on the unit, be sure that the electric supply is disconnected.

INSPECTION

When installing or servicing the unit, it is necessary to strictly follow the rules reported on this manual, to conform to all the specifications of the labels on the unit, and to take any possible precautions of the case. Not observing the rules reported on this manual can create dangerous situations. After receiving the unit, immediately check its integrity. The unit left the factory in perfect condition; any eventual damage must be questioned to the carrier and recorded on the Delivery Note before it is signed. HIDROS must be informed, within 8 days, of the extent of the damage. The Customer should prepare a written statement of any severe damage.

LIFTING AND HANDLING

When unloading the unit, it is highly recommended to avoid any sudden move in order to protect refrigerant circuit, copper tubes or any other unit component. Units can be lifted by using a forklift or, in alternative, using belts, being sure that the method of lifting does not damage the lateral panels and the cover. It is important to keep the unit horizontal at all time to avoid damages to the internal components.

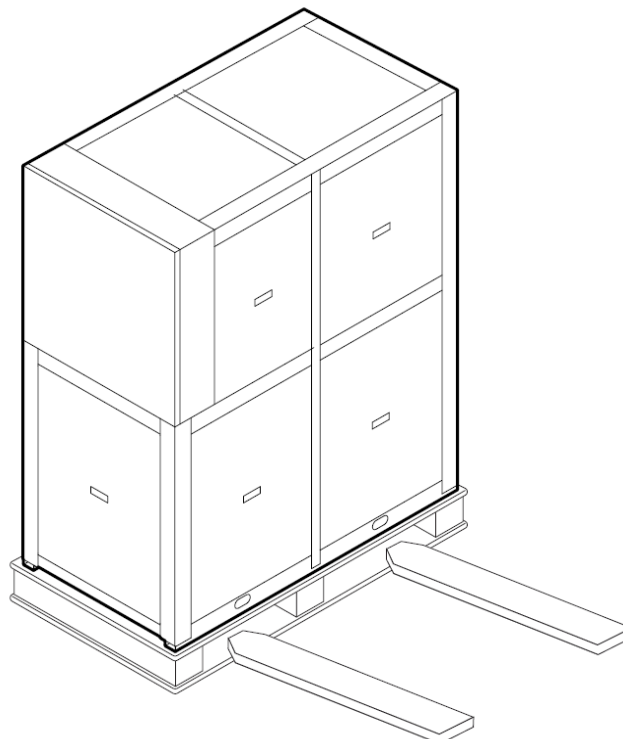

LOCATION AND MINIMUM TECHNICAL CLEARANCES

WDR units are designed for indoor installation. It is advisable to create a proper basement, with a size similar to unit foot-print. Unit vibration level is very low: it is advisable however, to fit a rigid rubber band between basement and unit base-frame. If it is the case, it is possible to install anti-vibration mounts (spring or rubber), to keep vibrations at a very low level. It is also necessary to observe the following clearances for service and maintenance:

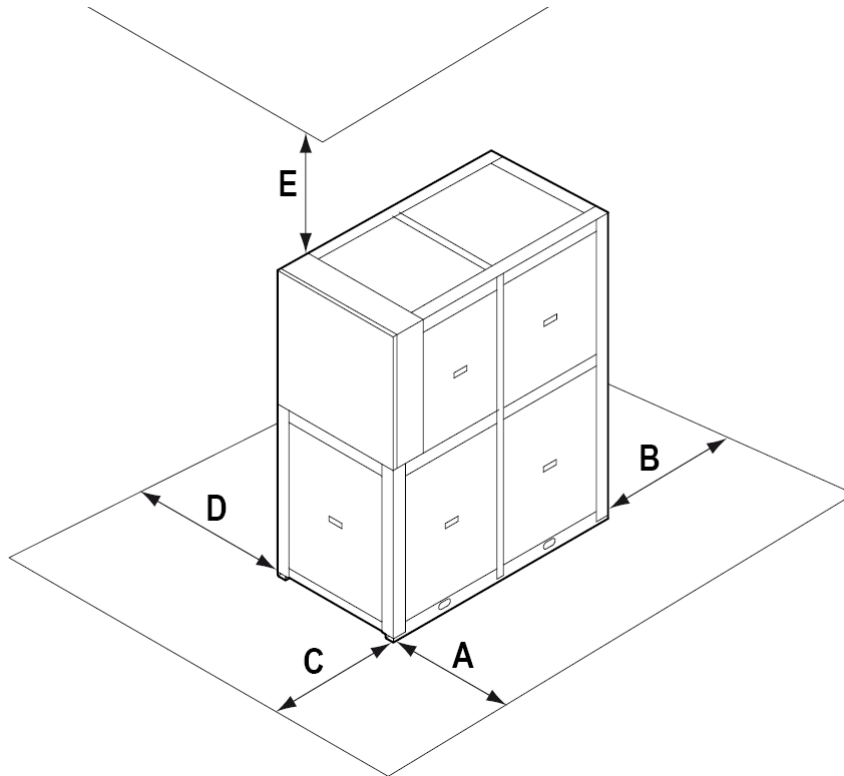

Mod.	A	B	C	D	E
039-045 -050-060-070-080-090-110-120-130	1000	500	600	0	500
144-164-190-210-240-260-300-320	1000	500	800	0	500



WARNING: The equipment should be installed so that maintenance and/or repair services be possible. The warranty does not cover costs due to lifting apparatus and platforms or other lifting systems required by the warranty interventions.



WARNING: All the maintenance operation must be done by TRAINED PEOPLE only.



WARNING: Before any service operation on the unit, be sure that the electric supply is disconnected.



WARNING: Inside the unit some moving components are present. Be very careful when operating in their surroundings even if the electric supply is disconnected.



WARNING: The top shell and discharge line of compressor are usually at high temperature level. Be very careful when operating in their surroundings.



WARNING: After servicing operation close the unit with cover panels, fixing them with locking screws.

HYDRAULIC CIRCUIT

Unit water pipe-work must be installed in accordance with national and local regulation, pipes can be made either in steel , galvanized steel or PVC. Pipes have to be designed depending on the nominal waterflow and the hydraulic pressure drops of the system. All pipes must be insulated with closed-cell material of adequate thickness. The unit has to be connected to the piping by using flexible joints. Piping should include:

- Temperature and pressure gauges for the ordinary maintenance or servicing operations.
- Shut-off manual valves to separate the unit from the hydraulic circuit.
- Metallic filters to be mounted on the inlet pipe with a mesh not larger than 1 mm.
- Vent valves, expansion tank with water filling, discharge valve.

The installation of the following accessories is also recommended: Water tank for economic operation and constant user water temperature (P); Hydraulic circuit manual shut-off valves (D); Air separator with safety valve (H); Automatic system feeder with pressure gauge (A);



WARNING: Unit water inlet must be in correspondence with the connection labelled: "USER WATER IN", otherwise the heat exchangers may freeze.



WARNING: It is compulsory to install on the evaporator and the condenser inlet connections a metallic filter with a mesh not larger than 1 mm. **THE FILTER IS MANDATORY**, the warranty will no longer be valid if it is not present or removed. The filter must be kept clean, so make sure it is clean after the unit has been installed, and then check it periodically.



WARNING: All units are factory supplied with the evaporator flow switch. The flow switch **MUST BE INSTALLED** on the water outlet connection (labelled USER WATER OUT); If the flow switch is altered, removed, or the water filter should not be present on the unit, the warranty will be invalidated. Please refer to the wiring diagram for flow switch electric connections.



WARNING: Water flow in the evaporator **MUST BE CONSTANT**.

In the following picture there is a layout of the WDR hydraulic circuit to show the suggested devices.

LEGEND

A	System filling group	H	Vent valve
B	Thermometer	L	Water pump
C	Flexible connection	N	Evaporator
D	Ball shut-off valve	O	Flow switch
E	Water strainer	P	Water tank
F	Expansion vessel	Q	Condenser
G	Safety valve		

HYDRAULIC CIRCUIT WDR BASIC VERSION

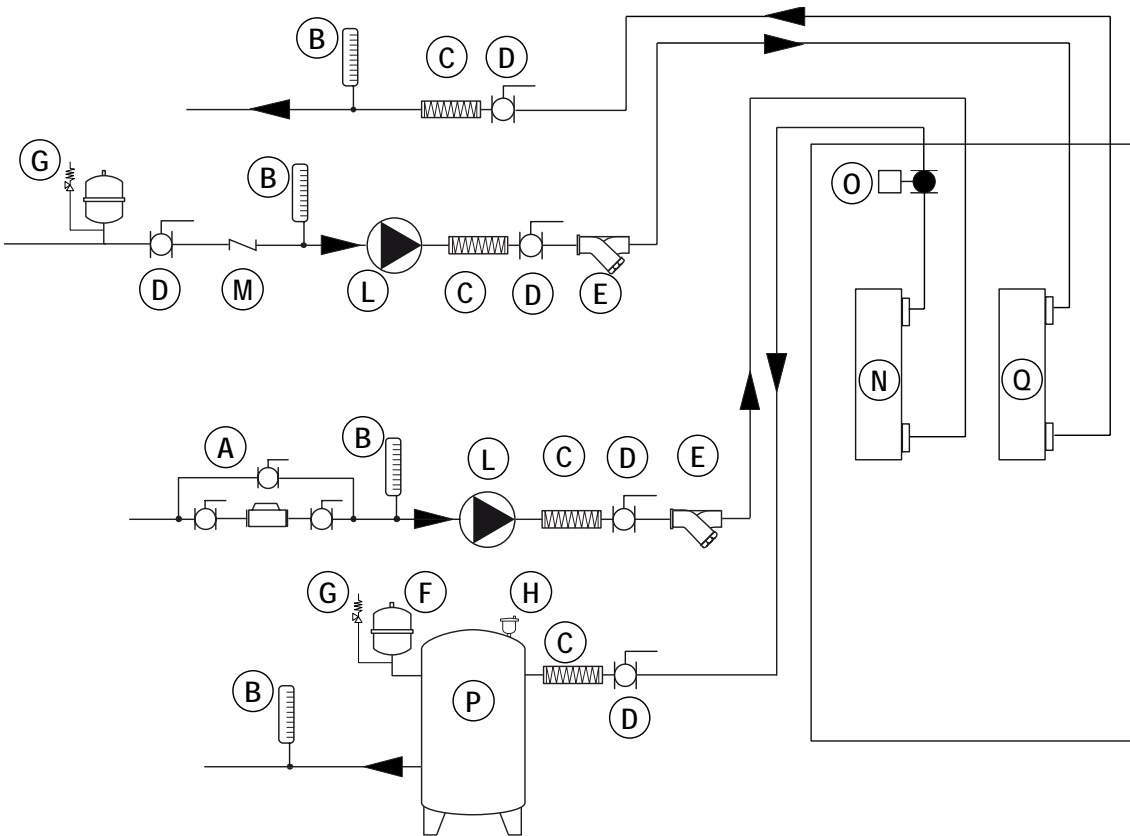

HYDRAULIC CIRCUIT WDR A1NT VERSION (WITH WATER PUMP)

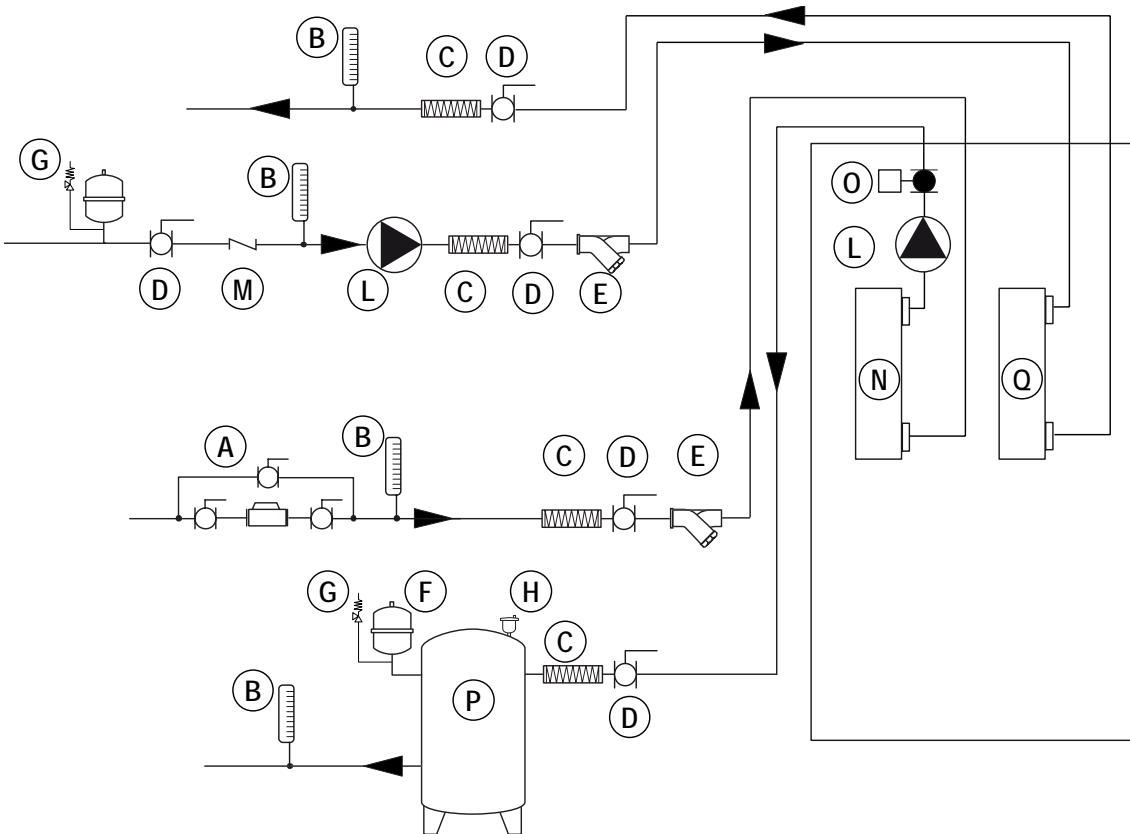

WDK / EV REFRIGERANT CONNECTIONS

Moto evaporating (EV versions) must be connected to a remote condenser by refrigerant lines. The moto evaporating (EV) units are supplied without refrigerant charge and filled with nitrogen. All models are supplied with microprocessor.

On split-system applications, piping layout is determined by sections location and building structure. Piping should be as shorter as possible in order to reduce pressure drops in refrigerant circuit and the refrigerant charge in the system. Maximum admitted pipe length is 30 meters.

WDR/EV units: remote condenser installed at a lower level than the compressors

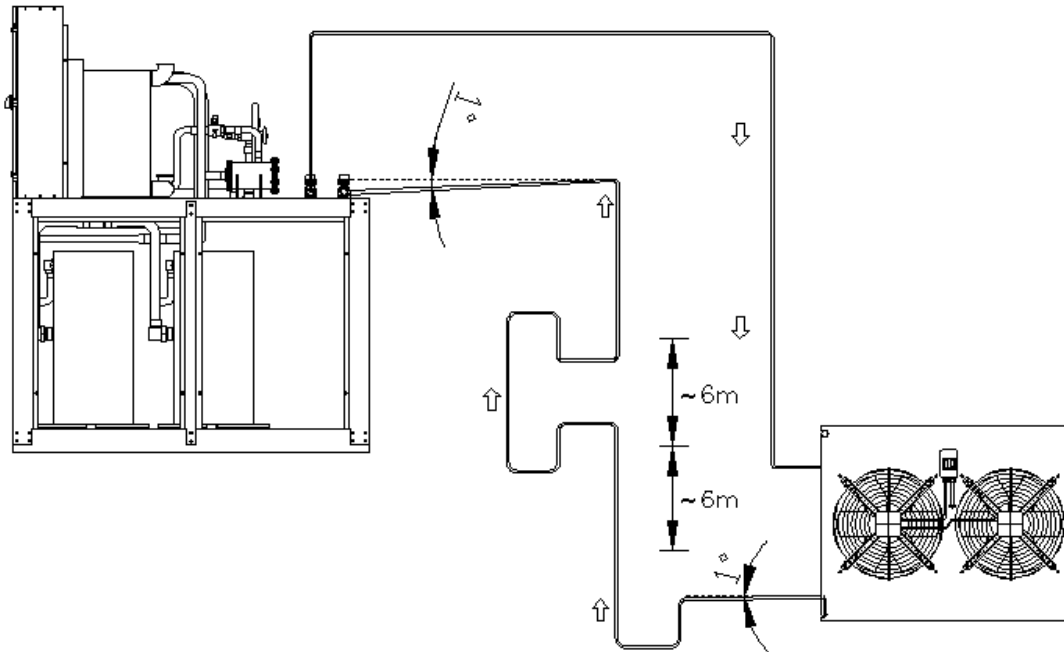

- On the rising vertical pipes, oil traps should be fitted every 6 metres to allow oil circulation in the system;
- On horizontal pipelines a minimum 1% slope should be allowed in order to drain oil in the proper flow direction.
- The refrigerant line diameters can be obtained by the refrigerant circuit, depending on the selected size and the distance between the indoor and the outdoor unit.

Refrigerant line diameters for "EV" versions

Distance [m]	10		20		30	
	Supply [mm]	Liquid [mm]	Supply [mm]	Liquid [mm]	Supply [mm]	Liquid [mm]
039	22	16	22	16	22	16
045	22	18	22	18	22	18
050	22	18	22	18	22	18
060	28	22	28	22	28	22
070	28	22	28	22	28	22
080	28	22	28	22	28	22
090	35	28	35	28	35	28
110	35	28	35	28	35	28
120	35	28	35	28	35	28
130	35	28	35	28	35	28
152	35	28	35	28	42	28
162	35	28	35	28	42	28

Refrigerant line diameters for "EV" versions

Distance [m]	10		20		30	
	Supply [mm]	Liquid [mm]	Supply [mm]	Liquid [mm]	Supply [mm]	Liquid [mm]
152	35	28	35	28	42	28
162	35	28	35	28	42	28
144	28	22	28	22	28	22
164	28	22	28	22	28	22
190	35	28	35	28	35	28
210	35	28	35	28	35	28
240	35	28	35	28	35	28
260	35	28	35	28	35	28
300	35	28	35	28	42	28
320	35	28	35	28	42	28

WDR/EV units: remote condenser installed at a higher level than the compressors

- Install a collection pit on discharge and return line so that liquid refrigerant, when the system is not running, can be collected by this pit, avoiding its return to compressor heads, and possible failure;
- On horizontal pipelines a minimum 1% slope should be allowed in order to drain oil in the proper flow direction.

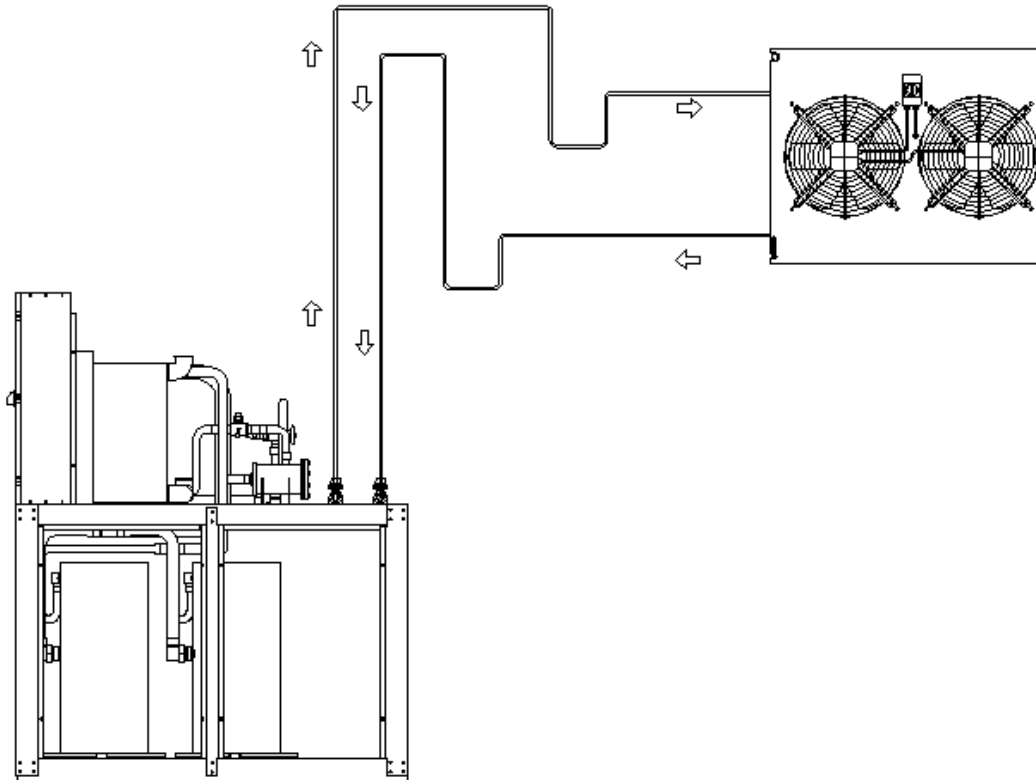

Refrigerant charge for liquid line

Liquid line diameter	Refrigerant charge g/m	Liquid line diameter	Refrigerant charge g/m
18 mm	220	28 mm	590
22 mm	360	35 mm	890

Cooling capacity correction factors

Mod.	Refr. Line 0 mt.	Refr. Line = 10 mt.	Refr. Line 20 mt.	Refr. Line 30 mt.
WDK / EV	1	0,98	0,96	0,95

UNIT DISPLAY

MODELS 039÷162



MODELS 144 ÷320



REMOTE CONTROL PANEL

MODELS 039÷162
Dimensions : 100 x 64 mm



MODELS 144 ÷320
Dimensions: 100 x 64 mm



WARNING: The remote control panel is connected to the water chiller by 2 wires of 2,5 mm² section. Power supply cables must be separated by remote control wires. Maximum distance 50 metres.



WARNING: The remote control panel can not be installed in area in with strong vibrations, corrosive gases, excess of dirtiness or high humidity level. Leave free the area near the cooling openings.

ELECTRICAL CONNECTIONS

It must be verified that electric supply is corresponding to the unit electric nominal data (tension, phases, frequency) reported on the label in the front panel of the unit. Power connections must be made in accordance to the wiring diagram enclosed with the unit and in accordance to the norms in force. Power cable and line protection must be sized according to the specification reported on the form of the wiring diagram enclosed with the unit.



WARNING: The line voltage fluctuations can not be more than $\pm 5\%$ of the nominal value, while the voltage unbalance between one phase and another can not exceed 2%. If those tolerances should not be respected, please contact our Company.



WARNING: Electric supply must be in the limits shown: in the opposite case warranty will terminate immediately. Before every operation on the electric section, be sure that the electric supply is disconnected.

WARNING: The Flow switch must be connected following the indication reported in the wiring diagram. Never bridge the flow switch connections in the terminal board. Guarantee will be invalidated if flow switch connections are altered or not properly made.

START UP

Before start-up

- Check that all power cables are properly connected and all terminals are hardly fixed.
- The voltage at the phase R S T is the one shown in the unit labels.
- Check that there is not any refrigerant leakage.
- Check that crankcase heaters are powered correctly.
- Check that all water connections are properly installed and all indications on unit labels are observed.
- The system must be bleed off in order to eliminate any air.
- Before proceeding to start up check that all the cover panels are re-located in the proper position and locked with fastening screws.



WARNING: Crankcase heaters must be powered at least 12 hours before start up by closing the main switch (heaters are automatically supplied when main switch is closed). The crankcase heaters are working properly if after some minutes the compressor crankcase temperature is about 10-15°C higher than ambient temperature

Start up

Please refer to the microprocessor manual enclosed with the unit.

If the unit should not start:

Check that the control thermostat is set to the correct value.



WARNING: Do not modify internal wiring of the unit otherwise warranty will terminate immediately.

Refrigerant charge checking

- After few hours the unit is working, check that sight glass shows a green colour core: if the core is yellow moisture would be present in the circuit. In this case it is necessary circuit dehydration to be carried out by qualified people only. Check that at the sight glass there is no continuous vapour bubbles presence. In this case additional refrigerant charge could be required. It is however allowed the presence of few vapour bubbles.
- Check that refrigerant superheat on the evaporator is about 5-7 °C
- Check if refrigerant sub-cooling on the condenser is about 5-7 °C.

Unit switch OFF

Please refer to the microprocessor manual enclosed with the unit.



WARNING: Never switch off the unit (for temporary stop), by opening the main switch: this component should be used only to disconnect the unit from power supply when the current is not passing through, i.e. when the unit is in OFF mode. Moreover, with no supply to crankcase heater, at the unit start up, compressor could be seriously damaged.

MAINTENANCE AND PERIODIC CHECKS



WARNING: All operations described in this chapter **MUST BE DONE BY TRAINED PEOPLE ONLY**. Before every operation of servicing on the unit, be sure that the electric supply is disconnected. The top shell and discharge line of compressor are usually at high temperature level. Be very careful when operating in their surroundings. After servicing operation close the unit with cover panels, fixing them with locking screws.

It is a good rule to carry on periodic checks in order to verify the correct operation of the unit.

- Check that safety and control devices work correctly as previously described (monthly).
- Check all the terminals on the electric board and on the compressor are properly fixed. Periodic cleaning of the sliding terminals of the contactors should be done.
- Verify refrigerant charge checking sight glass (monthly).
- Check there is no oil leakage from compressor (monthly).
- Check there is no water leakage in the hydraulic system (monthly).
- If the unit is to be expected to be stopped for a long period, unit hydraulic circuit should be emptied from all the tubes and heat exchanger. This operation is compulsory if, during seasonal stop, ambient temperature is expected to go down below the freezing point of employed mixture (typical seasonal operation).
- Check flow switch proper working (monthly).
- Check compressor crankcase heater proper supply and functioning (monthly).
- Clean metallic filters on water pipings (monthly).
- Check the colour of the sight glass core (green=no moisture, yellow=moisture present): if it has a yellow colour, change the refrigerant filter (every 4 months).

REFRIGERANT CIRCUIT REPAIR

In the case that refrigerant circuit should be discharged, all the refrigerant must be recovered with proper machines. The system must be charged with nitrogen, using a gas bottle with a pressure reducing valve, until 15 bar pressure is reached. Any eventual leakage must be searched with a bubble leak finder. In case bubbles appear discharge the circuit before welding with proper alloys.



WARNING: Never use oxygen instead of nitrogen: explosions may occur.

ENVIRONMENT PROTECTION

According to European norms dealing with the use of depleting stratospheric ozone substances, it is forbidden to release refrigerants fluids in the atmosphere. They must be redelivered to the seller or to proper gathering points at the end of their operating life. Refrigerant R407C is mentioned among controlled substances and for this reason it must be subjected to said norms. **A particular care is recommended during service operations in order to reduce as much as possible any refrigerant loss.**

UNIT OUT OF SERVICE

Once the unit is arrived at the end of its life and needs to be removed or replaced, the following operations are recommended:

- the unit refrigerant has to be recovered by trained people and sent to proper collecting centre;
- compressor lubricating oil has to be recovered and sent to proper collecting centre;
- the frame and various components, if not usable any longer, have to be dismantled and divided according to their nature; particularly copper and aluminium, which are present in conspicuous quantity in the unit. These operations allow easy material recover and recycling process, reducing environmental impact.

FAULT FINDING

Please refer to the unit microprocessor manual.

VERSIONE STANDARD
VERSION STANDARD

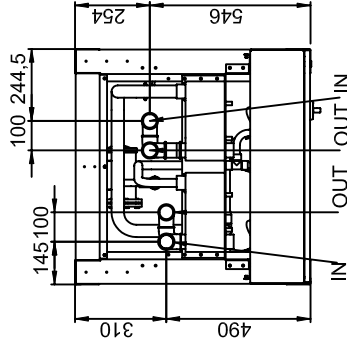
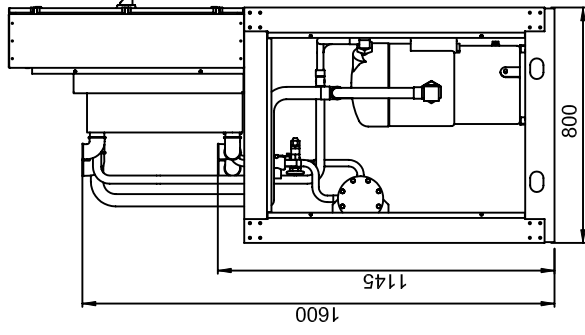
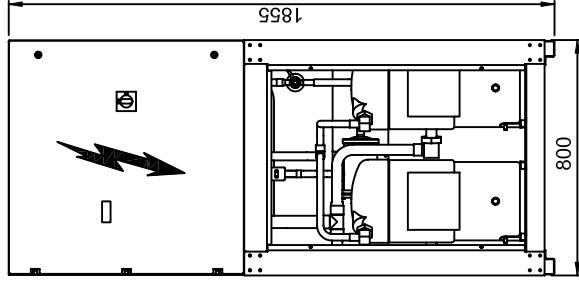

VERSIONE SILENZIATA
LOW NOISE VERSION

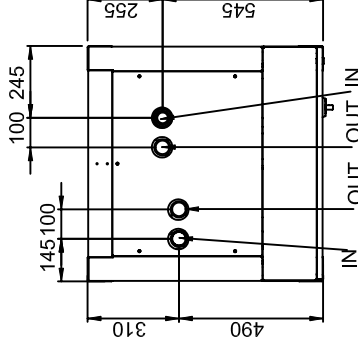
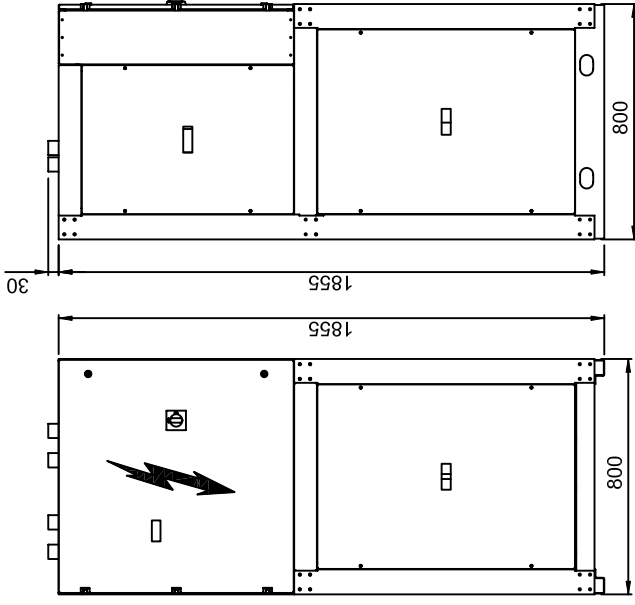

Descrizione modifica/Review description

Visto/Checked by

Dis./Draftsman

Data/Date

REV.
D
C
B

WDR / WDH

MODELLI	IN	OUT
039-045	1" 1/4	1" 1/4
050-060-070-080	1" 1/2	1" 1/2

Denominazione/Denomination

SHCEMA DIMENSIONALE WDR-H 039...080
DIMENSIONAL DRAWING WDR-H 039...080

Disegno/Drawing

SD.1WDR.0001A

Sost. il dis./Replace draw.

Rev. --

Foglio Sheet N. 1 of 1

Scala/Scale --

Form. -



Dis./Draftsman

Visto/Checked by

Ordine-Order

VERSIONE STANDARD
VERSION STANDARD

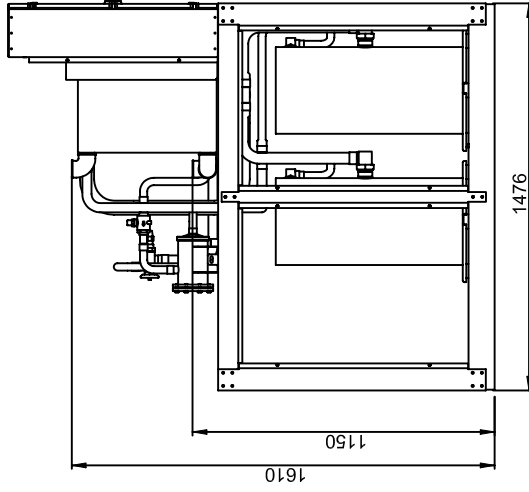
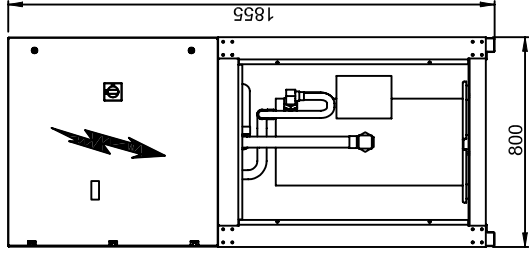

VERSIONE SILENZIATA
LOW NOISE VERSION

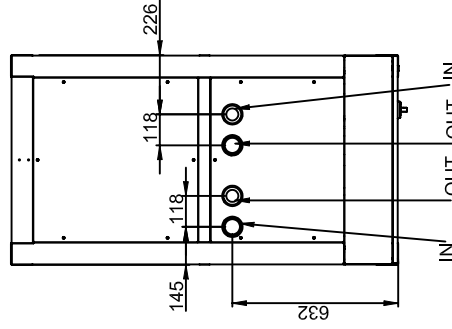
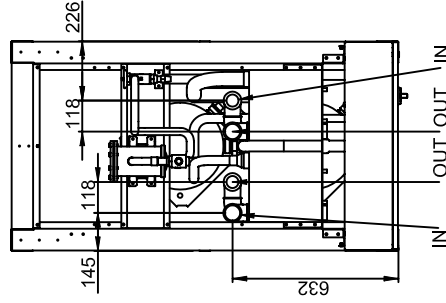
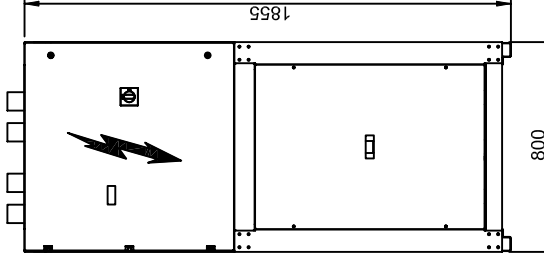
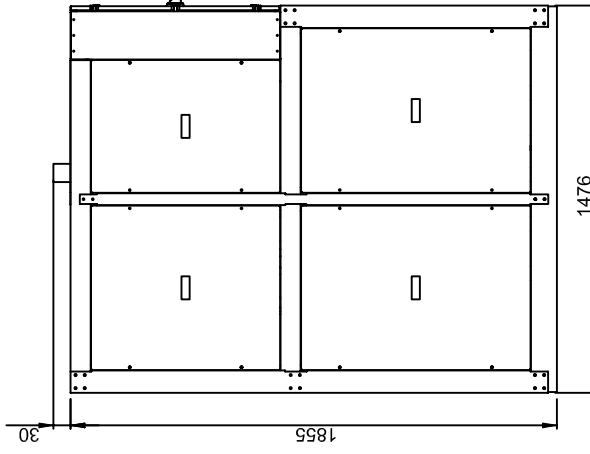

REV.					
0					
1					
2					
3					
4					
5					
6					
7					
8					
9					

Descrizione modifica/Review description

Visto/Checked by

Dis./Draftsman

Data/Date

MODELLI	IN	OUT
090-110-120-130	2"	2"
142-162	2" 1/2	2" 1/2

WDR / WDH

Denominazione/Denomination

SHCEMA DIMENSIONALE WDR-H 090... 162
DIMENSIONAL DRAWING WDR-H 090... 162

Disegno/Drawing

SD.1WDR.0005A

Sost. il dis./Replace draw.

Rev.

--

Sost. dal dis./Replaced by draw.

Data/Date

--

Dis./Draftsman

Foglio Sheet

N. 1 di 1

Scala/Scale

Form.

--

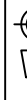

Visto/Checked by

Ordine-Order

VERSIONE STANDARD
VERSION STANDARD

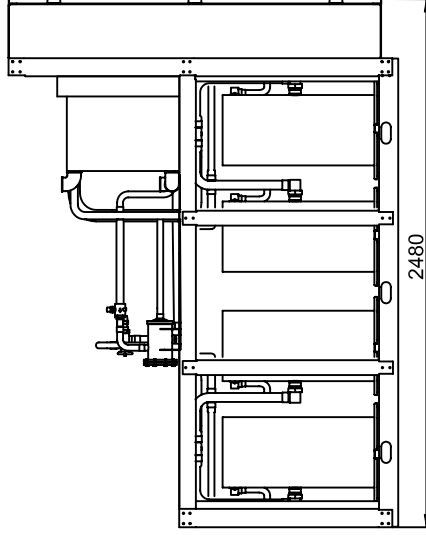
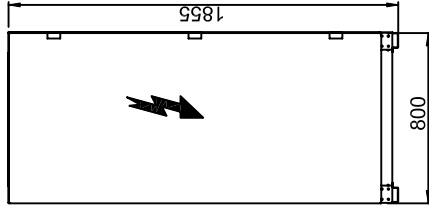

VERSIONE SILENZIATA
LOW NOISE VERSION

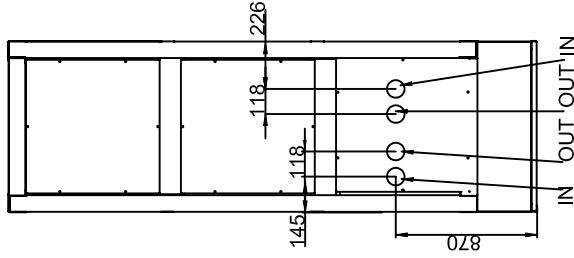
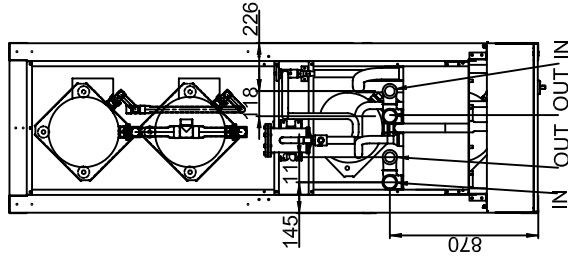
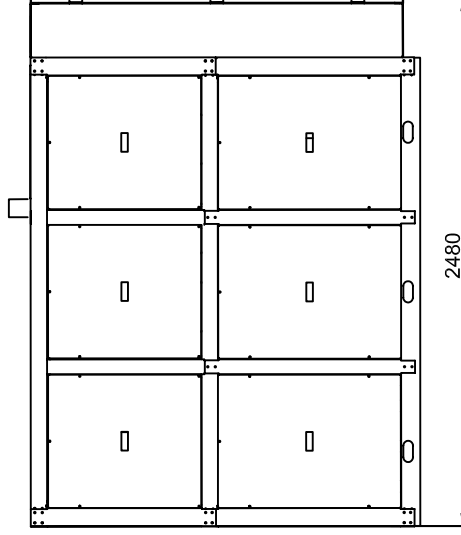
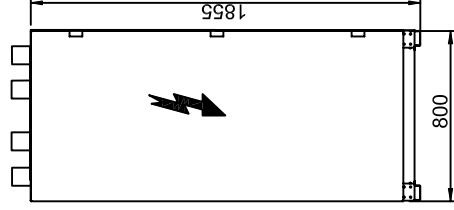

Descrizione modifica/Review description

Visto/Checked by

Dis./Draftsman

Data/Date

REV.
D
C
B

MODELLI	WDR / WDH		
	IN	OUT	
190-210	2" 1/2	2" 1/2	
240-260	3"	3"	
300-320	4"	4"	

Denominazione/Denomination

SHCEMA DIMENSIONALE WDR-H 190...320
DIMENSIONAL DRAWING WDR-H 190...320

Disegno/Drawing
SD.1WDR.0010A
Sost. il dis./Replace draw.

Rev. --
Data/Date --
Sost. dal dis./Replaced by draw.

Foglio Sheet N. 1 di 1
Scala/Scale --
Form. --
Visto/Checked by

Dis./Draftsman

Ordine-Order



Ferroli spa ▸ 37047 San Bonifacio (Verona) Italy ▸ Via Ritonda 78/A
tel. +39.045.6139411 ▸ fax +39.045.6100933 ▸ www.ferroli.it

Technical data shown in this booklet are not binding.
HIDROS SRL shall have the right to introduce at any time whatever modifications necessary to the improvement of the product.