



UT-REC

HEAT-RECOVERY UNITS
WITH SINGLE LAYER PANEL



TECHNICAL MANUAL

INTRODUCTION

These horizontal **UT-REC** heat-recovery units are compact and easy to fit which makes them ideal for false-ceilings in residential and commercial applications. **UT-REC** units combine maximum ambient comfort with guaranteed energy savings. Existing air-treatment and conditioning systems require forced ventilation which results in the treated air being expelled, involving high energy consumption and increased costs. The **UT-REC** series is designed to solve these problems by using a static heat-recovery unit that saves over 50% of the energy which would otherwise be wasted. These units, which can easily be incorporated into conventional systems made up of fan coils, radiators and conditioning units, operate in both winter and summer mode. The **UT-REC** series includes seven models which offer air flow rates ranging from 250 m³/h to 3200 m³/h. The high static pressures generated enable ducting to be installed which allows air to be extracted from or admitted into several rooms.

CONTENTS

1	TECHNICAL FEATURES	page	4
1.1	General features	"	4
1.2	Overall dimensions	"	5
1.3	Technical data	"	6
1.4	Possible configurations	"	7
1.5	By-pass for defrosting or free cooling	"	8
2	CAPACITY PERFORMANCE	"	9
2.1	Capacity model UT-REC 33	"	9
2.2	Capacity model UT-REC 55	"	9
2.3	Capacity model UT-REC 110	"	10
2.4	Capacity model UT-REC 175	"	11
2.5	Capacity model UT-REC 220	"	12
2.6	Capacity model UT-REC 255	"	13
2.7	Capacity model UT-REC 320	"	14
3	AIR FLOW PERFORMANCES	"	15
3.1	Air flow charts model UT-REC 33	"	15
3.2	Air flow charts model UT-REC 55	"	16
3.3	Air flow charts model UT-REC 110	"	16
3.4	Air flow charts model UT-REC 175	"	16
3.5	Air flow charts model UT-REC 220	"	17
3.6	Air flow charts model UT-REC 255	"	17
3.7	Air flow charts model UT-REC 320	"	17
4	ACCESSORIES	"	18
4.1	Electric post-heating resistance - BE	"	19
4.2	Post heating water coil - BW	"	19
4.3	Control dumper - SER	"	22
4.4	Single-phase speed controller - VVM-300W/VVM-600W	"	22
4.5	Speed switch - COM3	"	22
4.6	Unit control panel - PCO	"	23
4.7	Control dumper - PC+PE	"	23

1. TECHNICAL FEATURES

1.1 GENERAL FEATURES

- The structure is made of Aluzink.
- A suitably thick layer of polyethylene and polystyrene inside the appliance provides sound-proofing and heat insulation.
- The filters can easily be extracted from the side for periodic cleaning.
- The double-intake centrifugal electric fans (single-intake in the case of Models 33 and 55) have impellers that are both statically and dynamically balanced to cut vibration and noise to a minimum.
- The electric motors are directly coupled to the fan and all operate at three speeds, with the exception of Models 33 and 55 which operate at one speed.
- Models 33 and 55 are fitted with circular connections (as shown in the photograph below). For the other models, see the picture on page 5.
- The appliance comes with a power board to make it easy to achieve the electrical connections and, if required, to operate the fans by remote control. This board is not fitted on Models 33 and 55.



UT-REC Recovery unit

1.2 Overall Dimensions

MODEL DIMENSIONS		UT-REC 33	UT-REC 55	UT-REC 110	UT-REC 175	UT-REC 220	UT-REC 255	UT-REC 320
Ø	mm	160	200	—	—	—	—	—
Øi	mm	460	355	—	—	—	—	—
A	mm	990	990	1140	1300	1380	1650	1650
B	mm	290	290	410	500	500	600	600
C	mm	750	750	860	860	960	1230	1230
D	mm	—	—	260	290	310	410	410
E	mm	—	—	210	310	330	410	410
F	mm	—	—	220	225	225	288	321
G	mm	—	—	200	255	255	255	280
D1	mm	—	—	95	77	87	91	91
F1	mm	—	—	115	109	129	152	135
Y	mm	—	—	50	75	75	162	125
H	mm	—	—	800	799	900	1169	1169
I	mm	—	—	1075	1239	1320	1587	1587
G1	Ø GAS	—	—	3/4	3/4	3/4	3/4	3/4
Weight	kg	41	45	80	120	125	160	174

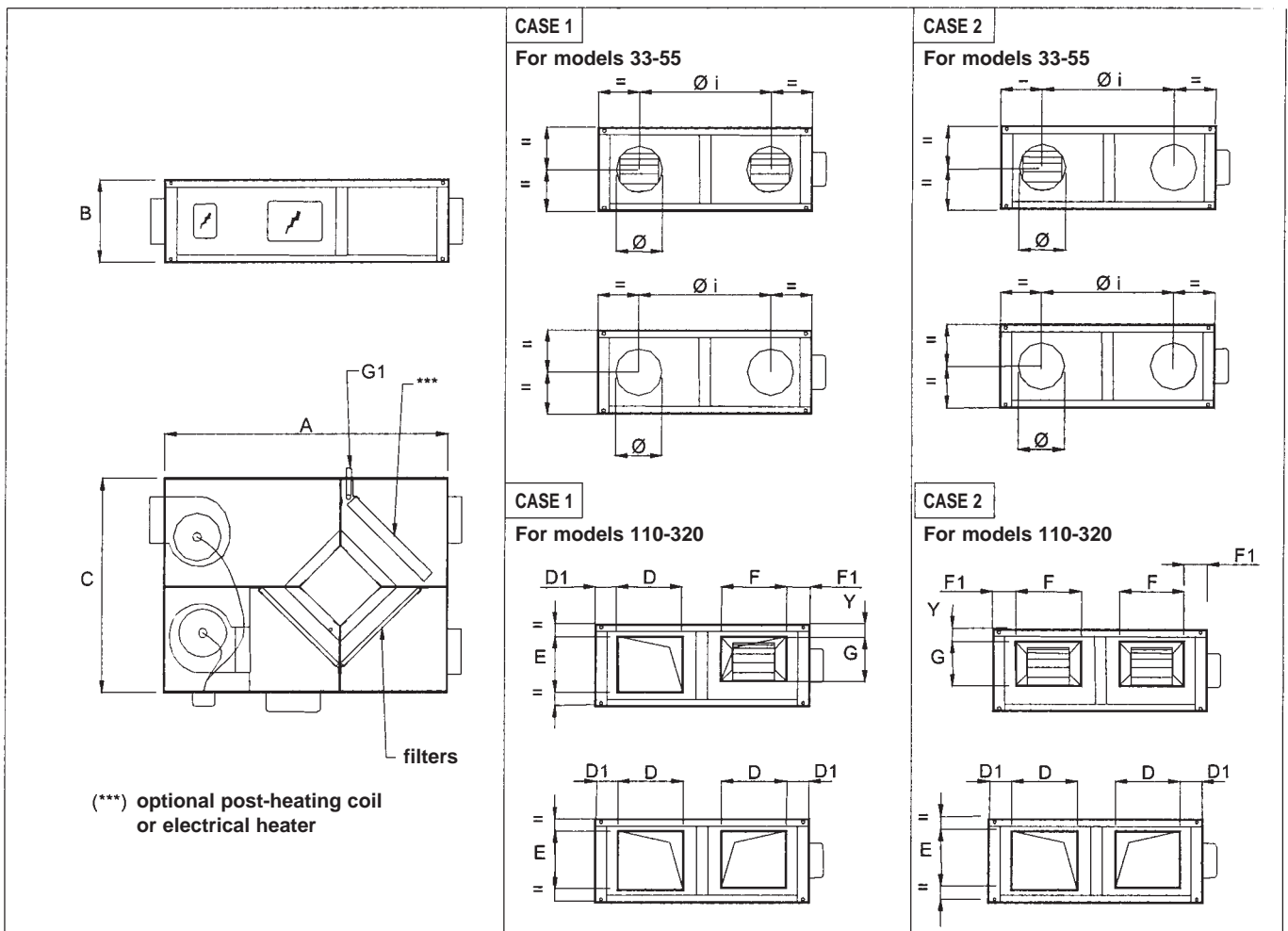

1.3 Technical data

MODEL		UT-REC 33	UT-REC 55	UT-REC 110	UT-REC 175	UT-REC 220	UT-REC 255	UT-REC 320
Air flow	m ³ /h	290	570	1050	1650	2120	2600	3150
Available static pressure*	Pa	50	65	80	100	100	110	120
Max. current input	A	0,75	1,80	2,2	4,5	4,8	5,2	8,3

FAN		UT-REC 33	UT-REC 55	UT-REC 110	UT-REC 175	UT-REC 220	UT-REC 255	UT-REC 320
Available shaft power	W	92 ^Δ	170 ^Δ	147	350	350	350	550
Poles	No.	4	4	4	4	4	4	4
Fan speeds	No.	1	1	3	3	3	3	3
International protection	IP	44	44	44	44	44	55	44
Insulation class		F	F	F	F	F	F	F
Power supply	V/ph/Hz	230/1/50						

HEAT-RECOVERY UNIT**		UT-REC 33	UT-REC 55	UT-REC 110	UT-REC 175	UT-REC 220	UT-REC 255	UT-REC 320
Efficiency	%	53	54	54	52	53	53	51
Capacity	kW	1,4	2,7	4,6	7,6	9,6	11,4	14,0
Fresh air outlet temp.	°C	8,2	8,7	8,5	8,1	8,0	8,1	8,0

FILTERS		UT-REC 33	UT-REC 55	UT-REC 110	UT-REC 175	UT-REC 220	UT-REC 255	UT-REC 320
Efficiency	EU	3	3	3	3	3	3	3
Air front speed	m/s	0,9	1,7	2,0	2,3	2,7	1,8	2,5

* Values refer to the rated air flow rate after the recovery unit and filters

** Values at the following nominal conditions: outside air T = -5°C, ambient air T = 20°C; nominal air flow rate

Δ Mains power input

1.4 Possible configurations

There is a choice of four possible positions for the recovery unit, depending on the configuration of the system and the space available, as illustrated below.

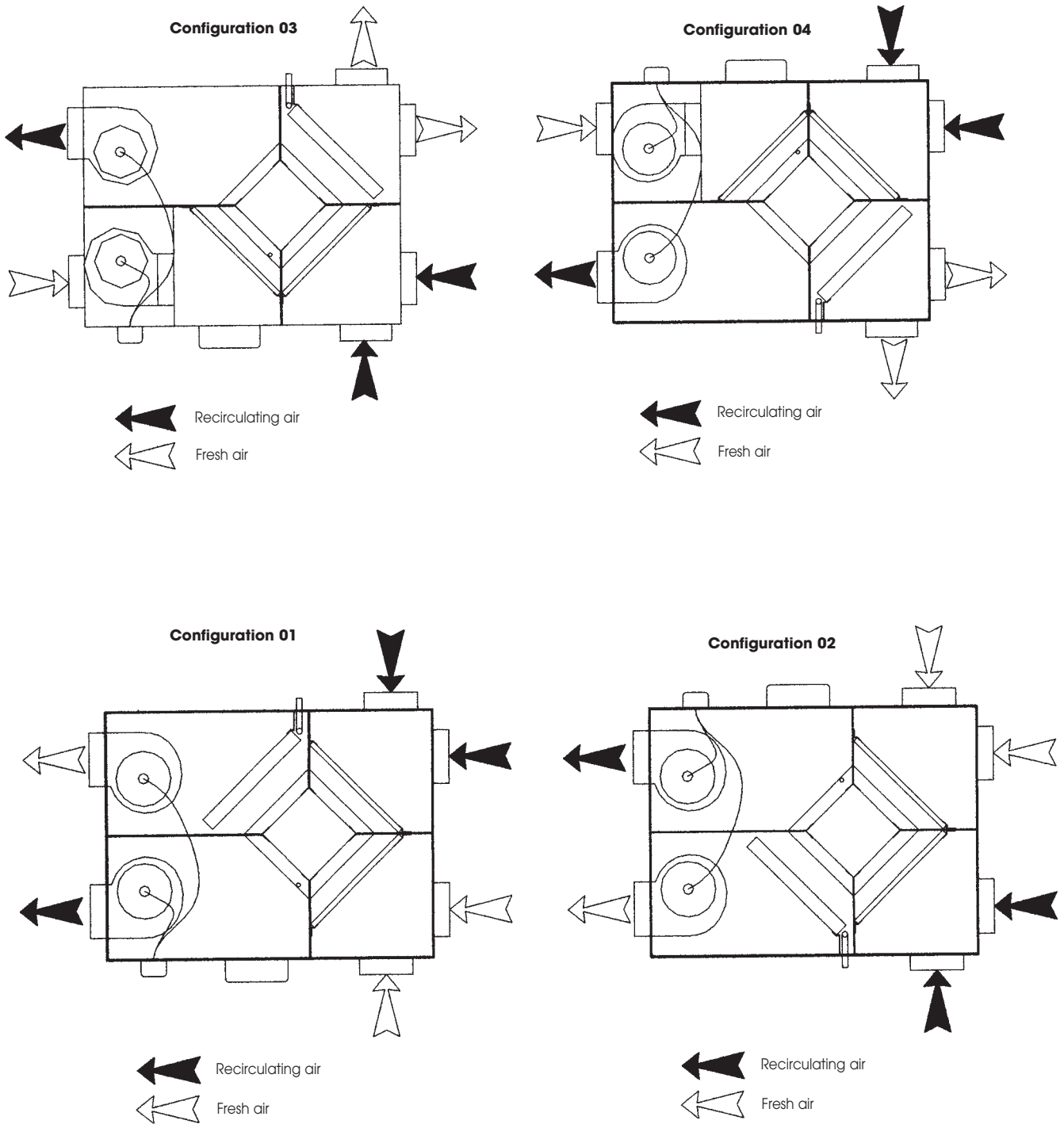

Air can be taken in or expelled both at the front and at the side simply by changing the position of the panels.

1.5 By-pass for defrosting or free cooling

There is a pre-cut slot in the framework of Models UT-REC 110, 175, 220, 255 & 320 to accommodate a by-pass for defrosting or free cooling.

Free cooling - When the temperature of the inlet air approaches the temperature of the expelled air, the recovery unit can be by-passed by emitting the fresh air straight into the room. This is achieved by closing Shutter A and opening Shutter B.

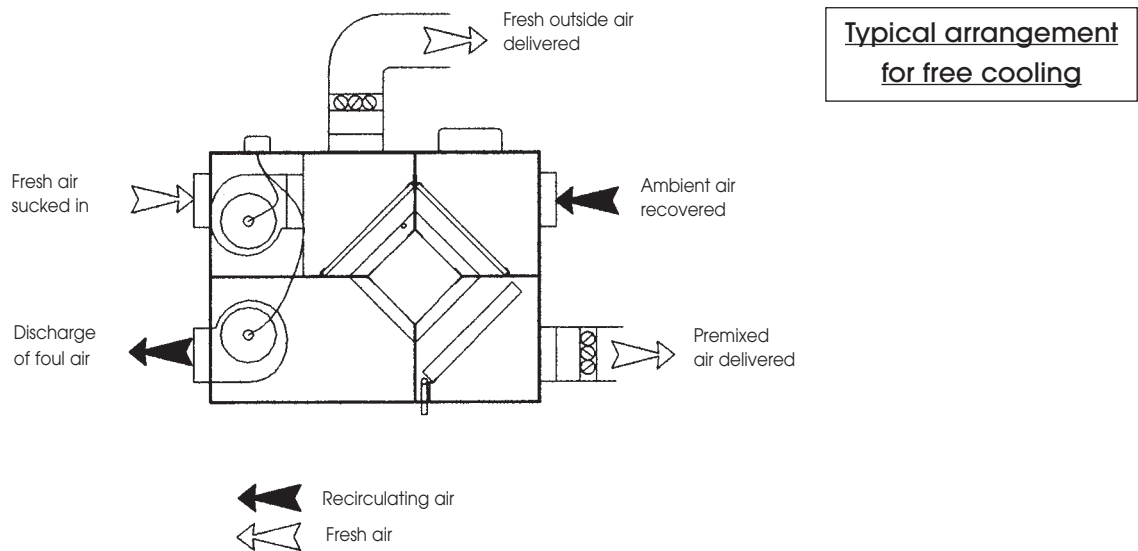

Defrosting - When the incoming air is very cold, the recovery unit could freeze. By fitting a TA anti-freeze thermostat and creating the by-pass system shown in the figure below, the recovery unit is defrosted. By closing Shutter A and opening Shutter B the cold air by passes the recovery unit, thus enabling the latter to be defrosted by the air expelled from the room.

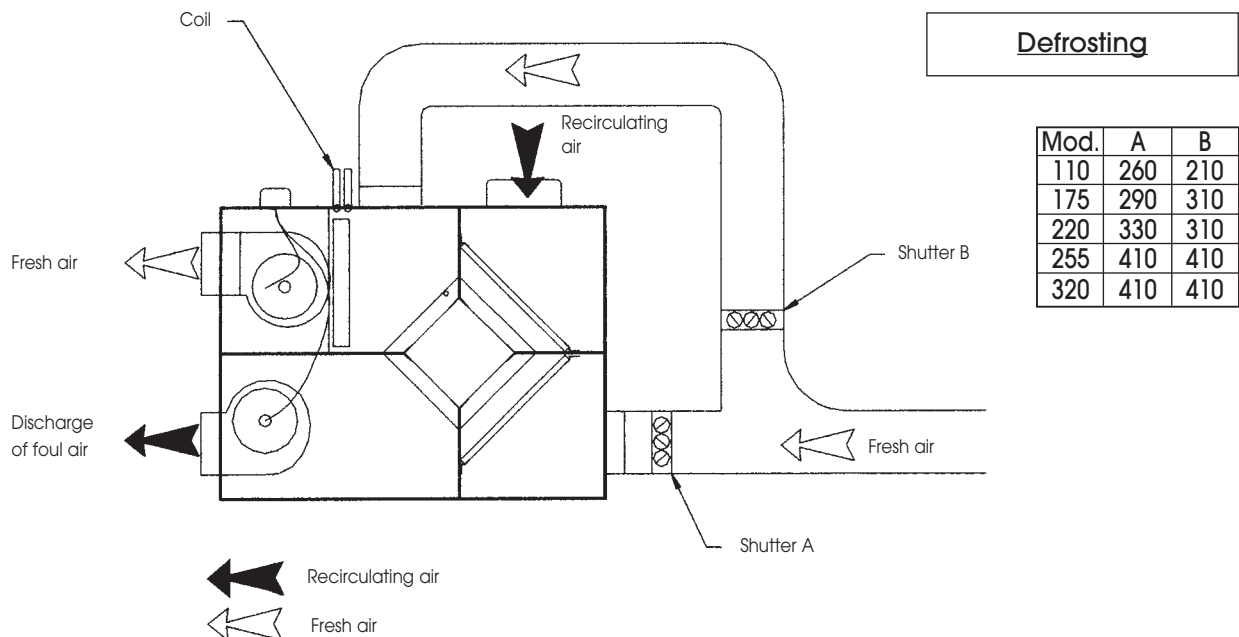

2. CAPACITY PERFORMANCE

2.1 Capacity Model UT-REC 33

Air flow	Ambient air	Fresh air		Treated air	Efficiency	Capacity
m ³ /h	°C	°C	R.H. %	°C	%	W
290	20	-10	80	6,1	53,8	1650
290	20	-5	80	8,1	52,3	1330
290	20	0	70	9,7	48,4	990
290	20	5	60	11,9	46,2	710
290	20	10	50	14,6	46,2	470
290	26	28	50	27,1	46,2	90
290	26	30	50	28,2	46,2	190
290	26	32	50	29,2	46,2	280
290	26	34	50	30,3	46,2	380

2.2 Capacity Model UT-REC 55

Air flow	Ambient air	Fresh air		Treated air	Efficiency	Capacity
m ³ /h	°C	°C	R.H. %	°C	%	W
600	20	-10	80	6,7	55,7	3410
600	20	-5	80	8,6	54,2	2760
600	20	0	70	10,0	50,1	2040
600	20	5	60	12,2	47,7	1460
600	20	10	50	14,8	47,7	970
600	26	28	50	27,0	47,7	190
600	26	30	50	28,1	47,7	390
600	26	32	50	29,1	47,7	580
600	26	34	50	30,2	47,7	780

2.3 Capacity Model UT-REC 110

Air flow	Ambient air	Fresh air		Treated air	Efficiency	Capacity
m ³ /h	°C	°C	R.H. %	°C	%	W
800	20	-10	80	6,8	56	4570
800	20	-5	80	8,6	54,5	3710
800	20	0	70	10,1	50,3	2740
800	20	5	60	12,2	47,9	1950
800	20	10	50	14,8	47,9	1300
800	26	28	50	27,0	47,9	260
800	26	30	50	28,1	47,9	520
800	26	32	50	29,1	47,9	780
800	26	34	50	30,2	47,9	1040
930	20	-10	80	6,6	55,4	5090
930	20	-5	80	8,5	53,9	4120
930	20	0	70	10,0	49,8	3050
930	20	5	60	12,1	47,4	2180
930	20	10	50	14,7	47,4	1450
930	26	28	50	27,1	47,4	290
930	26	30	50	28,1	47,4	580
930	26	32	50	29,2	47,4	870
930	26	34	50	30,2	47,4	1160
1050	20	-10	80	6,3	54,4	6100
1050	20	-5	80	8,2	52,9	4950
1050	20	0	70	9,8	48,9	3660
1050	20	5	60	12,0	46,7	2620
1050	20	10	50	14,7	46,7	1750
1050	26	28	50	27,1	46,7	350
1050	26	30	50	28,1	46,7	700
1050	26	32	50	29,2	46,7	1050
1050	26	34	50	30,3	46,7	1400

2.4 Capacity Model UT-REC 175

Air flow	Ambient air	Fresh air		Treated air	Efficiency	Capacity
m ³ /h	°C	°C	R.H. %	°C	%	W
1000	20	-10	80	6,8	55,9	5700
1000	20	-5	80	8,6	54,4	4620
1000	20	0	70	10,0	50,2	3410
1000	20	5	60	12,2	47,8	2440
1000	20	10	50	14,8	47,8	1630
1000	26	28	50	27,0	47,8	330
1000	26	30	50	28,1	47,8	650
1000	26	32	50	29,1	47,8	980
1000	26	34	50	30,2	47,8	1300
1350	20	-10	80	6,3	54,2	7740
1350	20	-5	80	8,2	52,7	6270
1350	20	0	70	9,7	48,7	4640
1350	20	5	60	12,0	46,5	3320
1350	20	10	50	14,7	46,5	2210
1350	26	28	50	27,1	46,5	440
1350	26	30	50	28,1	46,5	890
1350	26	32	50	29,2	46,5	1330
1350	26	34	50	30,3	46,5	1770
1700	20	-10	80	6,0	53,2	9220
1700	20	-5	80	7,9	51,7	7470
1700	20	0	70	9,6	47,9	5540
1700	20	5	60	11,9	45,7	3960
1700	20	10	50	14,6	45,7	2640
1700	26	28	50	27,1	45,7	530
1700	26	30	50	28,2	45,7	1060
1700	26	32	50	29,3	45,7	1580
1700	26	34	50	30,3	45,7	2110

2.5 Capacity Model UT-REC 220

Air flow	Ambient air	Fresh air		Treated air	Efficiency	Capacity
m ³ /h	°C	°C	R.H. %	°C	%	W
1100	20	-10	80	7,3	57,7	7060
1100	20	-5	80	9,1	56,2	5730
1100	20	0	70	10,6	52,8	4310
1100	20	5	60	12,4	49,2	3010
1100	20	10	50	14,9	49,2	2010
1100	26	28	50	27,0	49,2	400
1100	26	30	50	28,0	49,2	800
1100	26	32	50	29,0	49,2	1200
1100	26	34	50	30,1	49,2	1610
1400	20	-10	80	7,0	56,7	8100
1400	20	-5	80	8,8	55,2	6570
1400	20	0	70	10,2	50,9	4850
1400	20	5	60	12,3	48,5	3460
1400	20	10	50	14,9	48,5	2310
1400	26	28	50	27,0	48,5	460
1400	26	30	50	28,1	48,5	920
1400	26	32	50	29,1	48,5	1390
1400	26	34	50	30,1	48,5	1850
2100	20	-10	80	6,1	53,8	12070
2100	20	-5	80	8,1	52,3	9780
2100	20	0	70	9,7	48,4	7240
2100	20	5	60	11,9	46,2	5180
2100	20	10	50	14,6	46,2	3460
2100	26	28	50	27,1	46,2	690
2100	26	30	50	28,2	46,2	1380
2100	26	32	50	29,2	46,2	2070
2100	26	34	50	30,3	46,2	2760

2.6 Capacity Model UT-REC 255

Air flow	Ambient air	Fresh air		Treated air	Efficiency	Capacity
m ³ /h	°C	°C	R.H. %	°C	%	W
1150	20	-10	80	7,8	59,5	7000
1150	20	-5	80	9,5	58,0	5700
1150	20	0	70	10,3	53,4	4200
1150	20	5	60	12,6	50,6	3000
1150	20	10	50	14,9	50,6	2000
1150	26	28	50	27,0	50,6	400
1150	26	30	50	28,0	50,6	800
1150	26	32	50	29,1	50,6	1200
1150	26	34	50	30,1	50,6	1600
1750	20	-10	80	6,9	56,3	10340
1750	20	-5	80	8,7	54,8	8380
1750	20	0	70	10,1	50,5	6180
1750	20	5	60	12,2	48,1	4420
1750	20	10	50	14,8	48,1	2940
1750	26	28	50	27,0	48,1	590
1750	26	30	50	28,1	48,1	1180
1750	26	32	50	29,1	48,1	1770
1750	26	34	50	30,2	48,1	2350
2450	20	-10	80	6,2	54,1	13800
2450	20	-5	80	8,2	52,6	11180
2450	20	0	70	9,7	48,7	8280
2450	20	5	60	12,0	46,4	5920
2450	20	10	50	14,6	46,4	3940
2450	26	28	50	27,1	46,4	790
2450	26	30	50	28,1	46,4	1580
2450	26	32	50	29,2	46,4	2370
2450	26	34	50	30,3	46,4	3160

2.7 Capacity Model UT-REC 320

Air flow	Ambient air	Fresh air		Treated air	Efficiency	Capacity
m ³ /h	°C	°C	R.H. %	°C	%	W
2100	20	-10	80	6,5	55	12340
2100	20	-5	80	8,4	53,5	10000
2100	20	0	70	9,9	49,4	7390
2100	20	5	60	12,1	47,1	5280
2100	20	10	50	14,7	47,1	3520
2100	26	28	50	27,1	47,1	700
2100	26	30	50	28,1	47,1	1410
2100	26	32	50	29,2	47,1	2110
2100	26	34	50	30,2	47,1	2820
2600	20	-10	80	6,2	53,9	14290
2600	20	-5	80	8,1	52,4	11580
2600	20	0	70	9,7	48,4	8560
2600	20	5	60	11,9	46,2	6130
2600	20	10	50	14,6	46,2	4080
2600	26	28	50	27,1	46,2	820
2600	26	30	50	28,2	46,2	1630
2600	26	32	50	29,2	46,2	2450
2600	26	34	50	30,3	46,2	3270
3150	20	-10	80	5,8	52,5	17140
3150	20	-5	80	7,8	51	13870
3150	20	0	70	9,4	47,2	10270
3150	20	5	60	11,8	45,1	7360
3150	20	10	50	14,5	45,1	4910
3150	26	28	50	27,1	45,1	980
3150	26	30	50	28,2	45,1	1960
3150	26	32	50	29,3	45,1	2940
3150	26	34	50	30,4	45,1	3930

3. AIR FLOW PERFORMANCES

The air flow charts reproduced below show the residual working head for the various flow rates. The graphs take into account the pressure loss on the air side of the heat recovery unit and filters.



UT-REC Motor/Fan Unit

3.1 Air flow charts Model UT-REC 33

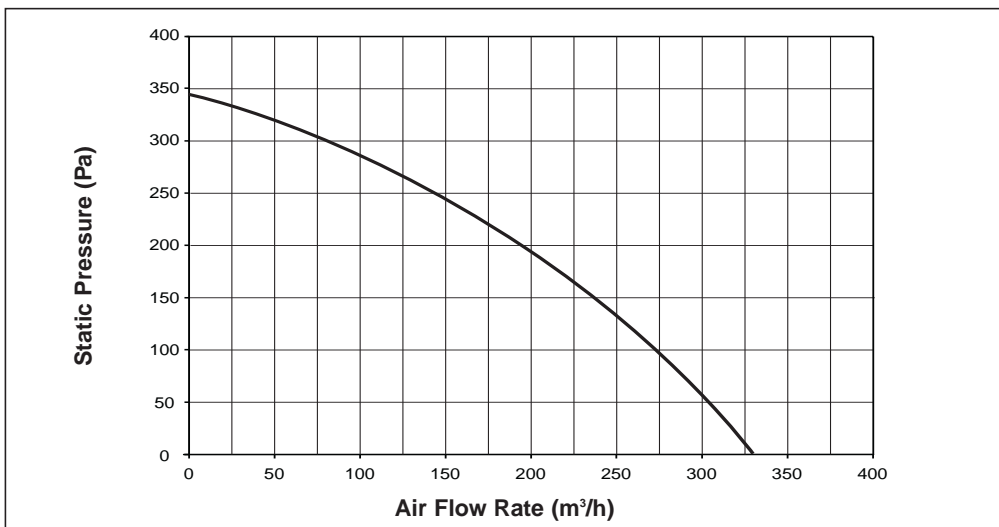

3.2 Air flow charts Model UT-REC 55

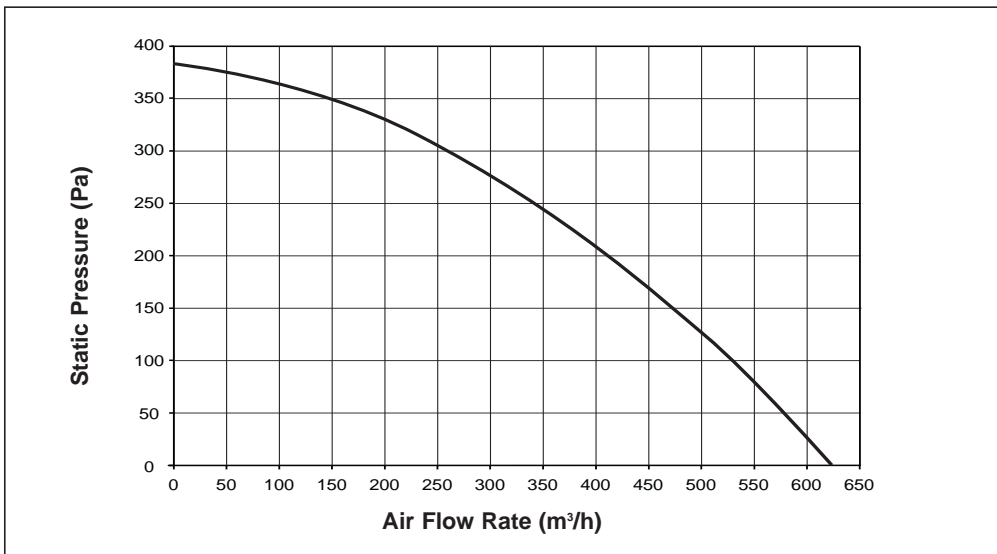

3.3 Air flow charts Model UT-REC 110

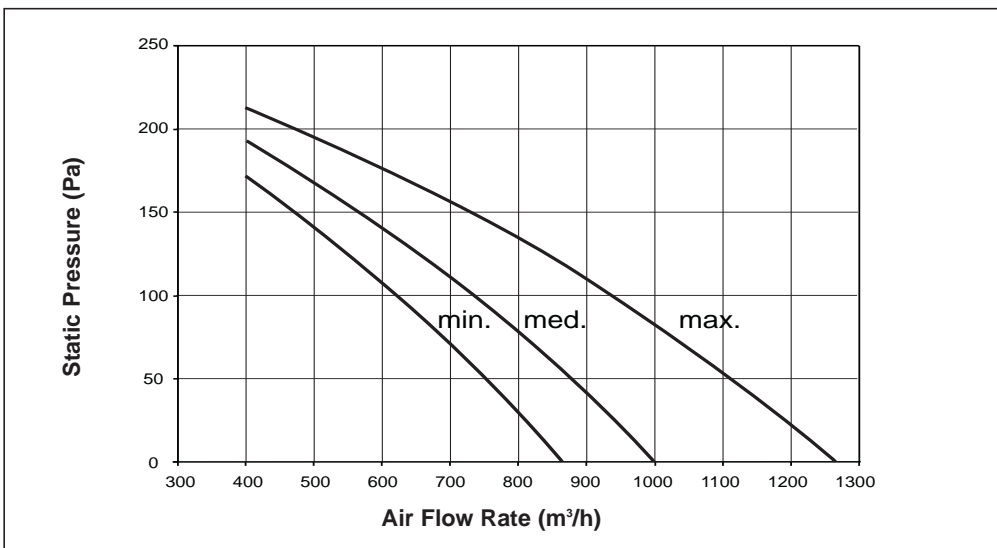

3.4 Air flow charts Model UT-REC 175

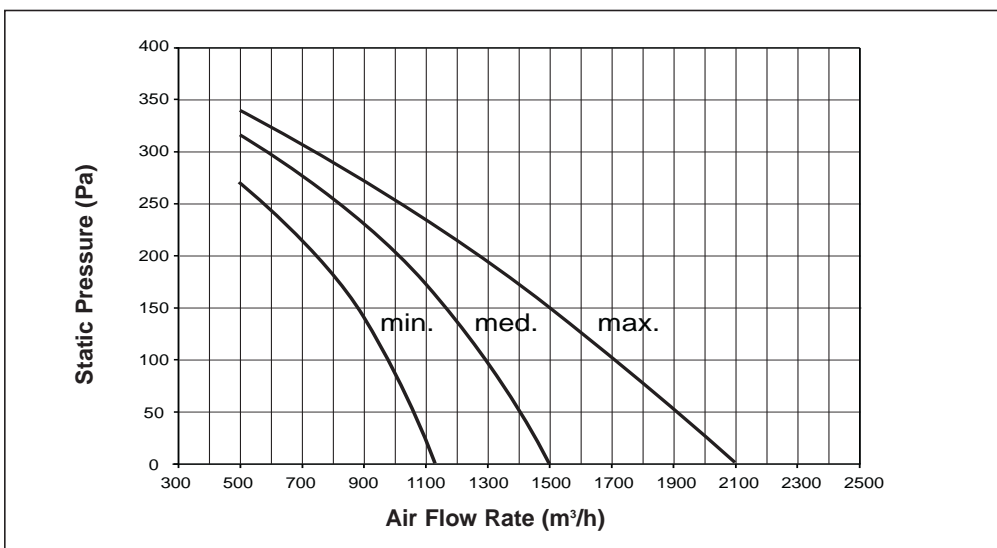

3.5 Air flow charts Model UT-REC 220

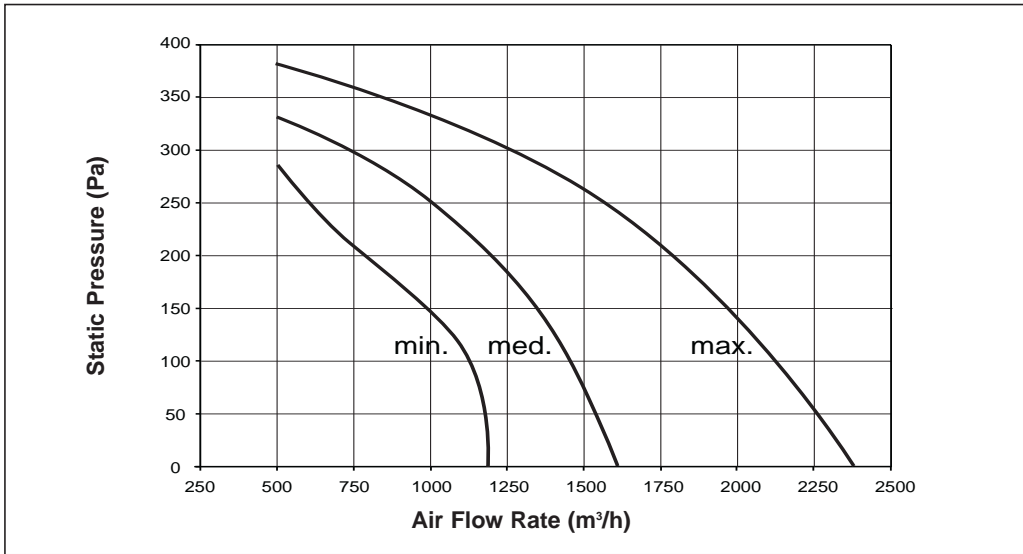

3.6 Air flow charts Model UT-REC 255

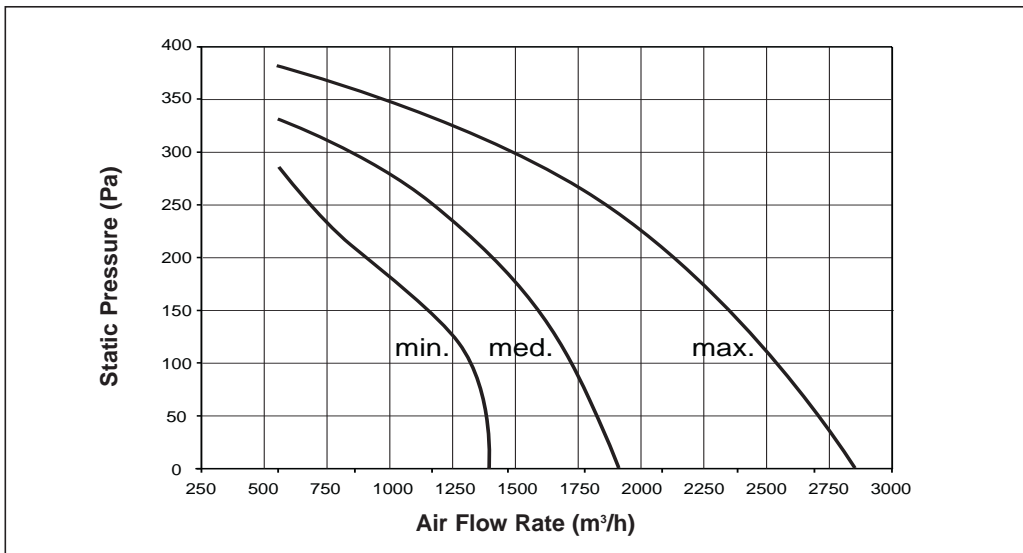

3.7 Air flow charts Model UT-REC 320

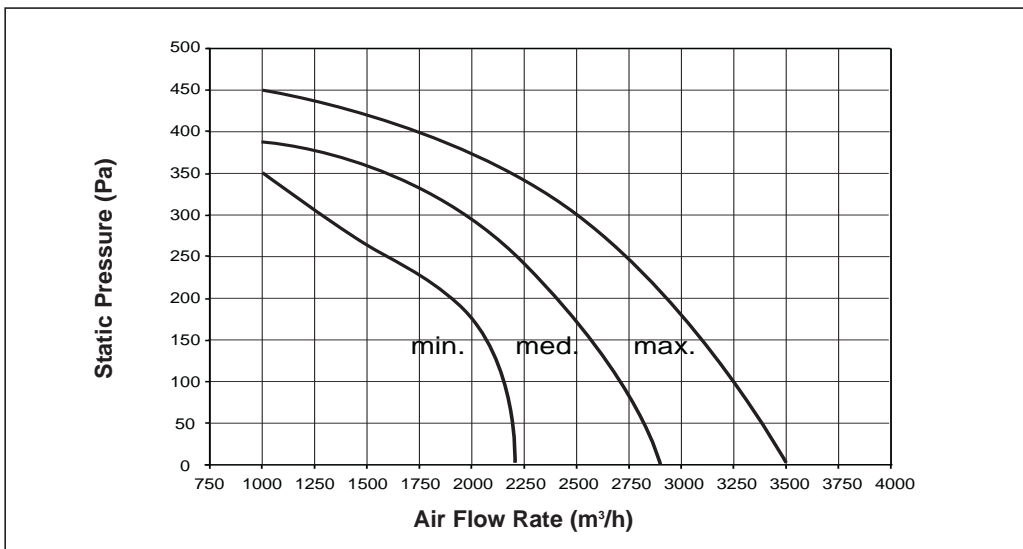

4. ACCESSORIES

- Electric post-heating resistance - **BE**
- Post-heating water coil - **BW**
- Control dumper - **SER**
- Dirty filters pressure switch - **PRF**
- Antifreeze thermostat - **TA**
- Single-phase speed controller
- Speed switch - **COM3**
- Unit control panel - **PCO**
- Unit control panel and electrical heating coil - **PC+PE**

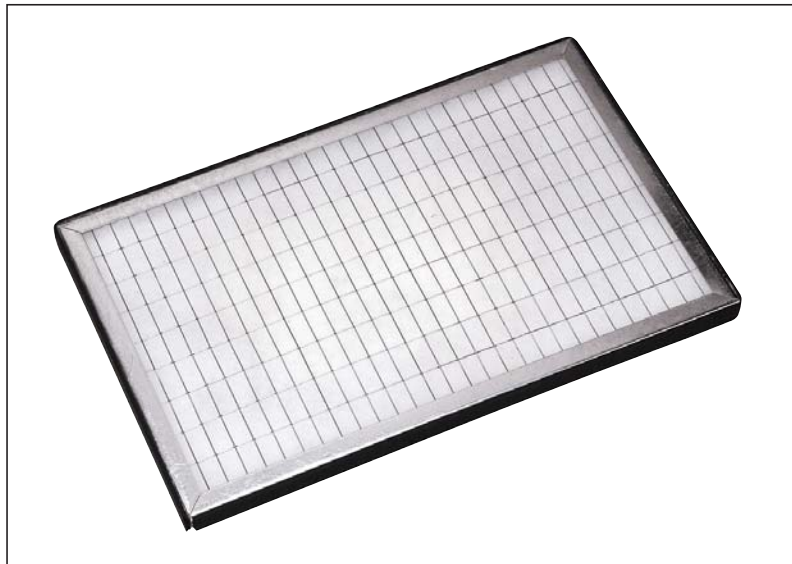

UT-REC Filter



UT-REC Recovery Unit

4.1 Electric post-heating resistance - BE

We recommend the use of a BE when post-heating is required but no water is available.

The BE is a filament heater designed to limit pressure loss.

This heater requires a 400/3/50 three-phase supply and can be controlled by the PCO control panel and comes complete with safety thermostats and control relays, whereas protection for the supply line must be provided by the installer.

ELECTRICAL HEATING COIL		UT-REC 33	UT-REC 55	UT-REC 110	UT-REC 175	UT-REC 220	UT-REC 255	UT-REC 320
Heating capacity	kW	1,5	3	3	6	6	12	12
Voltage	V	230	230	400	400	400	400	400
Phases	No.	1	1	3	3	3	3	3
Stages	No.	1	1	1	1	1	1	1
Current input	A	6,5	13,5	6,3	8,65	8,65	8,65	8,65
Air outlet temp. (*)	°C	23,3	24,2	16,5	18,8	16,4	22,3	19,3

(*) Value based on air inlet temp=8°C and nominal air flow rate

4.1.1 Air side pressure loss - BE Section

Pressure loss of the electrical coil ranges from 2 to 10 Pa.

4.2 Post heating water coil - BW

When post heating is necessary a BW coil is used, installed inside the recovery unit.

BW COIL (*)		UT-REC 110	UT-REC 175	UT-REC 220	UT-REC 255	UT-REC 320
Rows	No.	2	2	2	2	2
Heating capacity	kW	9,0	12,0	13,9	21,0	24,6
Air outlet temp.	°C	32,8	30,0	29,0	33,0	31,0
Air side pressure drop	Pa	25	32	38	24	36
Water side pressure drop	kPa	8	14	16	16	22

* Values at the following nominal conditions: water 70-60°C; air inlet temp=8°C; nominal air flow rate

4.2.1 Heating capacity of Post-heating Coil Model UT-REC 110

Fixed Values				Calculated Values						
Water		Air		Air			Water			
IT w	OT w	Q v	IT ar	OT ar	V fa	Δp fa	m w	V w	Δp w	P
(°C)	(°C)	(m ³ /h)	(°C)	(°C)	(m/s)	(Pa)	(L/s)	(m/s)	(kPa)	(kW)
70	60	1050	6	30,3	2,6	34	0,20	0,95	10	9.2
70	60	1050	8	32,8	2,6	34	0,19	0,92	9	9.0
70	60	1050	10	32,9	2,6	34	0,19	0,88	9	8.8
70	60	1050	12	34,1	2,6	34	0,18	0,85	8	8.5
70	60	1050	20	39,0	2,6	35	0,15	0,72	6	7.1
45	40	1050	6	21,8	2,6	33	0,25	1,15	15	6.0
45	40	1050	8	23,0	2,6	33	0,23	1,09	14	5.7
45	40	1050	10	24,2	2,6	33	0,22	1,03	12	5.2
45	40	1050	12	25,5	2,6	34	0,21	0,96	11	5.0
45	40	1050	20	30,3	2,6	35	0,15	0,70	6	4.5

4.2.2 Heating capacity of Post-heating Coil Model UT-REC 175

Fixed Values				Calculated Values						
Water		Air		Air			Water			
IT w	OT w	Q v	IT ar	OT ar	V fa	Δp fa	m w	V w	Δp w	P
(°C)	(°C)	(m ³ /h)	(°C)	(°C)	(m/s)	(Pa)	(L/s)	(m/s)	(kPa)	(kW)
70	60	1650	6	29,2	2,8	32	0,32	1,13	14	13.2
70	60	1650	8	30,4	2,8	32	0,31	1,10	14	12.0
70	60	1650	10	31,7	2,8	32	0,30	1,06	13	11.8
70	60	1650	12	32,9	2,8	33	0,29	1,02	12	11,7
70	60	1650	20	37,7	2,8	34	0,25	0,87	9	11,7
45	40	1650	6	20,3	2,8	31	0,39	1,39	22	8,5
45	40	1650	8	21,5	2,8	31	0,37	1,31	20	8,1
45	40	1650	10	22,7	2,8	32	0,35	1,24	18	7,8
45	40	1650	12	23,9	2,8	32	0,33	1,16	16	7,2
45	40	1650	20	28,7	2,8	33	0,24	0,85	9	5,2

4.2.3 Heating capacity of Post-heating Coil Model UT-REC 220

Fixed Values				Calculated Values						
Water		Air		Air			Water			
IT w	OT w	Q v	IT ar	OT ar	V fa	Δp fa	m w	V w	Δp w	P
(°C)	(°C)	(m ³ /h)	(°C)	(°C)	(m/s)	(Pa)	(L/s)	(m/s)	(kPa)	(kW)
70	60	2120	6	27,6	3,2	48	0,37	1,30	17	14,9
70	60	2120	8	28,9	3,2	48	0,36	1,26	16	13,9
70	60	2120	10	30,2	3,2	48	0,35	1,22	15	13,7
70	60	2120	12	31,5	3,2	49	0,33	1,17	14	13,3
70	60	2120	20	36,7	3,2	50	0,28	0,99	10	12,9
45	40	2120	6	19,7	3,2	47	0,45	1,59	26	10,1
45	40	2120	8	21,0	3,2	47	0,43	1,51	24	9,5
45	40	2120	10	22,3	3,2	48	0,40	1,42	21	9,3
45	40	2120	12	23,6	3,2	48	0,38	1,33	19	8,7
45	40	2120	20	28,7	3,2	49	0,28	0,97	11	5,8

4.2.4 Heating capacity of Post-heating Coil Model UT-REC 255

Fixed Values				Calculated Values						
Water		Air		Air			Water			
IT w	OT w	Q v	IT ar	OT ar	V fa	Δp fa	m w	V w	Δp w	P
(°C)	(°C)	(m ³ /h)	(°C)	(°C)	(m/s)	(Pa)	(L/s)	(m/s)	(kPa)	(kW)
70	60	2600	6	31,7	2,3	25	0,55	1,28	19	22,1
70	60	2600	8	32,9	2,3	25	0,53	1,24	18	21,0
70	60	2600	10	34,0	2,3	26	0,51	1,20	17	20,6
70	60	2600	12	35,2	2,3	26	0,49	1,15	16	20,2
70	60	2600	20	39,7	2,3	26	0,42	0,98	12	18,5
45	40	2600	6	21,9	2,3	25	0,66	1,56	29	14,7
45	40	2600	8	23,0	2,3	25	0,63	1,48	27	13,0
45	40	2600	10	24,1	2,3	25	0,59	1,40	24	12,6
45	40	2600	12	25,3	2,3	25	0,56	1,30	21	11,8
45	40	2600	20	29,7	2,3	25	0,41	0,96	12	9,5

4.2.5 Heating capacity of Post-heating Coil Model UT-REC 320

Fixed Values				Calculated Values						
Water		Air		Air			Water			
IT w	OT w	Q v	IT ar	OT ar	V fa	Δp fa	m w	V w	Δp w	P
(°C)	(°C)	(m ³ /h)	(°C)	(°C)	(m/s)	(Pa)	(L/s)	(m/s)	(kPa)	(kW)
70	60	3150	6	29,5	2,8	36	0,61	1,44	23	25,2
70	60	3150	8	30,7	2,8	36	0,59	1,39	22	24,6
70	60	3150	10	31,9	2,8	36	0,57	1,35	21	23,8
70	60	3150	12	33,1	2,8	37	0,55	1,30	19	22,7
70	60	3150	20	37,9	2,8	38	0,47	1,11	15	19,4
45	40	3150	6	20,5	2,8	35	0,75	1,76	36	15,7
45	40	3150	8	21,7	2,8	36	0,71	1,67	33	14,7
45	40	3150	10	22,9	2,8	36	0,67	1,57	30	14,0
45	40	3150	12	24,1	2,8	36	0,63	1,47	26	13,2
45	40	3150	20	28,8	2,8	37	0,46	1,08	15	9,8

4.3 Control dumper - SER

The control dumper **SER** comprises a galvanised sheet steel frame with adjustable slats. This allows the air flow to be shut off and is used to create the by-pass arrangements described above.

4.3.1 Dimensions

MODEL	B (mm)	A (mm)
UT-REC 110	190	210
UT-REC 175	290	310
UT-REC 220	330	310
UT-REC 255-320	410	410

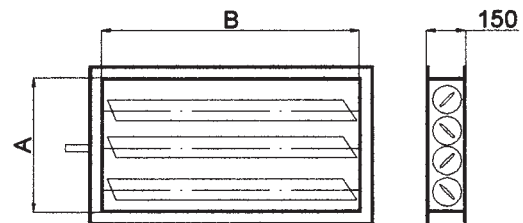

4.4 Speed controller

The speed controller is wall-mounted and enables the fan to be adjusted by the single-phase motor. There are three models of regulators depending on the power output of the fan motor: **1.5A, 3.0A & 5.0A**. The following controls are on the front panel:

- the ON/OFF switch
- the continuous speed adjustment knob

Models	V/ph/Hz	Nominal current	Maximum current	Range of adjustment
> 300 W	230/1/50	1,5 A	3A	40% a 100% Vmax
> 600 W	230/1/50	3 A	5A	40% a 100% Vmax

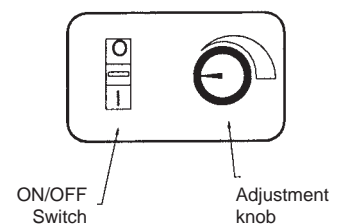

4.5 Speed Switch - COM3

This wall-mounted control enables the three speeds of the electric fan to be selected.

The COM3 has the following controls:

- ON/OFF switch
- three speed switch
(minimum, medium, maximum)
- 230V supply

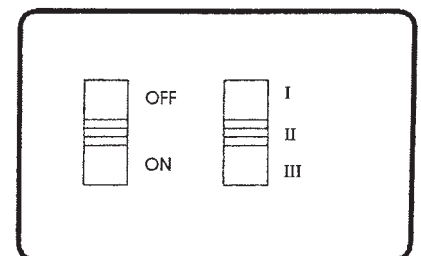

4.6 UNIT CONTROL PANEL - PCO

This wall-mounted device enables the ambient temperature to be controlled both in summer and winter mode. It also enables the three speeds of the electric fan to be selected (with the exception of Model 410 which only has high speed).

The following controls are on the front panel:

- Summer ❄️ - OFF 0 - Winter 🔥
- Temperature adjustment knob
- Three speed switch

Installation and assembly

1. Pull off the knob
2. Remove the cover
3. Release the plate attached to the base of the thermostat by unhooking and pushing it down at the same time
4. Fix the plate to the wall, at about 1.5 metres from the floor
5. Refit the cover by hooking it back on

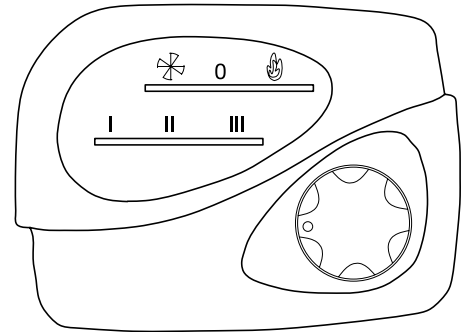

Technical features

Power Supply	230 -15%+10% Vac; 50/60 Hz
Output	3 W
International protection	IP 20
Adjustments	Manual Switch: Winter/Off/Summer Room Thermostat Knob Three-speed Switch: Min/Med/Max
Cut-out Relay	5A with resistive load

4.7 UNIT CONTROL PANEL + ELECTRICAL HEATING SECTION PC+PE

This wall-mounted device enables the ambient temperature to be controlled both in summer and winter mode. It also enables the electrical heater to be switched off or on and the three speeds of the electric fan to be selected.

The following controls are on the front panel:

- ON/OFF switch
- Temperature adjustment knob
- Three speed switch
- Winter switch with heater ❄️ 🔥 - Winter 🔥 - Summer ❄️

Installation and assembly

1. Pull off the knob
2. Undo the screw and remove the cover
3. Fix the base to the wall, at about 1.5 metres from the floor
4. Make the electrical connections
5. Refit the case and tighten the screw
6. Fit the knob

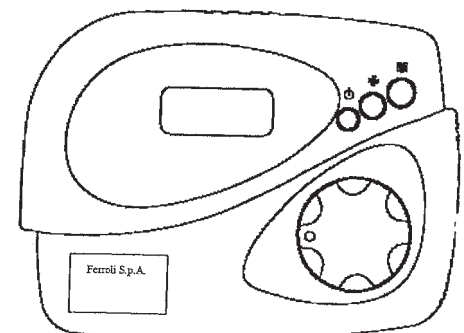

Technical characteristics

Power Supply	230 +/-10% Vac; 50/60 Hz
Adjustments	Manual Switch: ON/OFF Room thermostat knob Manual Switch: Winter with heater/Winter/Summer Three speed Switch: Min/Med/Max
Cut-out Relay	5A with resistive load



■
NOTE TO SALES REPRESENTATIVES

In an effort to constantly improve our range of products, with the aim of increasing the level of customer satisfaction, we would like to inform you that the appearance, dimensions, technical data, and accessories of our products may be subject to change.

Therefore, the utmost care must be taken to ensure that all technical and/or sales documents (price lists, catalogues, brochures, etc.) provided to the end client are completely up to date.

cod. 89NG0002/00 - 10.2006



Ferroli spa - 37047 San Bonifacio (Verona) Italy - Via Ritonda 78/A
tel. +39.045.6139411 - fax +39.045.6100233
www.gruppoferroli.com - e-mail: export@ferroli.it